



# DATA SHEET



## Medium Voltage Relay MVR-200 series



## 1. Product description

1.1 MVR-200 series controllers.....	5
1.2 Applications.....	5
1.3 Features.....	6

## 2. Protections

2.1 Current protections.....	8
2.1.1 Non-directional over-current (50/51) I>, I>>, I>>>, I>>>>.....	8
2.1.2 Non-directional earth fault (50N/51N) I0>, I0>>, I0>>>, I0>>>>.....	8
2.1.3 Directional over-current (67) IDIR>, IDIR>>, IDIR>>>, IDIR>>>>.....	9
2.1.4 Directional earth fault (67N) I0DIR>, I0DIR>>, I0DIR>>>, I0DIR>>>>.....	10
2.1.5 Current unbalance (46/46R/46L) I2>, I2>>, I2>>>, I2>>>>.....	11
2.1.6 Circuit breaker failure protection (50BF/52BF) CBFP.....	12
2.1.7 Restricted earth fault/cable end differential (87N) I0D>.....	13
2.1.8 Harmonic over-current (50H/51H, 68) IH>, IH>>, IH>>>, IH>>>>.....	13
2.2 Voltage protections.....	14
2.2.1 Under-voltage (27) U<, U<<, U<<<, U<<<<.....	14
2.2.2 Over-voltage (59) U>, U>>, U>>>, U>>>>.....	15
2.2.3 Neutral over-voltage (59N) U0>, U0>>, U0>>>, U0>>>>.....	16
2.2.4 Sequence voltage (47/27PN/59PN) U1/2>/< (1 to 4).....	16
2.2.5 Vector jump (78) ΔA>.....	17
2.3 Frequency protections.....	17
2.3.1 Over- or under-frequency (81O/81U) F>/<, F>>/<<, F>>>/<<<, F>>>>/<<<<.....	17
2.3.2 Rate of change of frequency (81R) df/dt >/< (1 to 8).....	18
2.4 Power protections.....	19
2.4.1 Over-, under- and reverse power (32/37) P>, P<, PREV>.....	19
2.4.2 Active, reactive and apparent power (32/37) PQS>/< (1 to 4).....	19
2.5 Feeder protections.....	20
2.5.1 Line thermal overload (49L) TF>.....	20
2.5.2 Intermittent earth fault (67NT) I0INT>.....	20
2.5.3 Auto-reclosing function (79) 0 → 1.....	21
2.5.4 Fault locator (21FL) X → km.....	22
2.6 Machine protections.....	22
2.6.1 Machine differential (87M) ID>.....	22
2.6.2 Machine thermal overload (49M) TM>.....	22
2.6.3 Power factor (55) PF<.....	23
2.7 Motor protections.....	24
2.7.1 Loss of load (37) I<.....	24
2.7.2 Mechanical jam (51M) Im>.....	24
2.7.3 Start/locked rotor (48,14) IST>.....	25
2.7.4 Frequent start protection (66/86) N>.....	25
2.8 Generator protections.....	26
2.8.1 Under-impedance (21) Z<.....	26
2.8.2 Over-excitation (24) V/HZ>.....	26
2.8.3 Under-excitation (40) Q<.....	27
2.8.4 Voltage-restrained over-current (51V) IV>.....	27
2.8.5 100 % stator earth fault protection (64S) U03RD<.....	28
2.8.6 Pole slip (78G) PS.....	29
2.9 Transformer protections.....	29

2.9.1 Transformer thermal overload (49T) T>.....	29
2.9.2 Transformer differential (87T,87R) IDB>, IDI>, HV I0D>, LV I0D>.....	30
2.9.3 Transformer differential (87G,87R) IDB>, IDI>, HV I0D>, LV I0D>.....	30
2.9.4 Transformer monitoring function (TRF).....	31
2.9.5 Under-impedance (21) Z<.....	31
2.9.6 Over-excitation (24) V/HZ>.....	32
2.9.7 Automatic voltage regulator (90) AVR (Transformer).....	33
<b>2.10 Control functions</b> .....	<b>33</b>
2.10.1 Synchrocheck (25) SYN1, SYN2, SYN3.....	33
2.10.2 Cold load pick-up (68) CLP.....	34
2.10.3 Switch on to fault (SOTF).....	34
2.10.4 Object control.....	35
2.10.5 Setting group selection.....	35
<b>2.11 Monitoring functions</b> .....	<b>35</b>
2.11.1 Fuse failure (60) VTS.....	35
2.11.2 Circuit breaker wear monitor (CBW).....	36
2.11.3 Disturbance recorder (DR).....	36
2.11.4 Current transformer supervision (CTS).....	37
2.11.5 Total harmonic distortion (THD).....	37
2.11.6 Voltage memory (integrated in 67,21G).....	38
<b>3. Technical specifications</b>	
<b>3.1 Electromagnetic compatibility</b> .....	<b>39</b>
<b>3.2 Mechanical durability</b> .....	<b>40</b>
<b>3.3 Environment</b> .....	<b>41</b>
<b>3.4 Safety</b> .....	<b>41</b>
<b>4. Hardware</b>	
<b>4.1 Auxiliary supply</b> .....	<b>43</b>
<b>4.2 Current measurement module</b> .....	<b>43</b>
<b>4.3 Voltage measurement module</b> .....	<b>44</b>
<b>4.4 Frequency, power and energy measurement accuracy</b> .....	<b>45</b>
<b>4.5 Digital inputs and outputs</b> .....	<b>45</b>
4.5.1 Isolated digital inputs with software settable threshold (Option card B).....	45
4.5.2 Normally open digital outputs (Option card C).....	45
4.5.3 Isolated digital inputs (PSU card).....	46
4.5.4 Changeover digital outputs (PSU card).....	46
<b>4.6 Analogue outputs</b> .....	<b>47</b>
4.6.1 Analogue output (option card I).....	47
<b>4.7 Communication options</b> .....	<b>47</b>
4.7.1 RS232 & Serial fiber communication module (Option card L to O).....	47
4.7.2 Double LC100 Mb Ethernet module (Redundant) (Option card J).....	47
<b>4.8 Communication ports</b> .....	<b>48</b>
<b>4.9 MVR-21x display</b> .....	<b>48</b>
4.9.1 Display.....	48
<b>4.10 MVR-25x display</b> .....	<b>49</b>
4.10.1 Display.....	49
<b>4.11 Folios and configuration</b> .....	<b>50</b>
<b>4.12 Mechanical specifications</b> .....	<b>51</b>

4.13 Environment.....	52
4.14 Safety.....	52
4.15 Dimensions.....	52
<b>5. Ordering information</b>	
5.1 MVR Ordering.....	54
5.2.1 Disclaimer.....	59
5.2.2 Copyright.....	59

# 1. Product description

## 1.1 MVR-200 series controllers

The MVR-200 series provides protection, control, measurement and monitoring for medium- and high-voltage applications. Modular hardware construction gives flexibility; functionality can be added or changed at any point. Multi-processor architecture is used to provide accurate protection and measurement.

## 1.2 Applications

DEIF medium voltages relays prevent hazards and equipment damage in all applications where a generator, transformer, motor and/or feeder is present. Four wiring examples and the ANSI functions are shown below.

Generator protection wiring (G257)

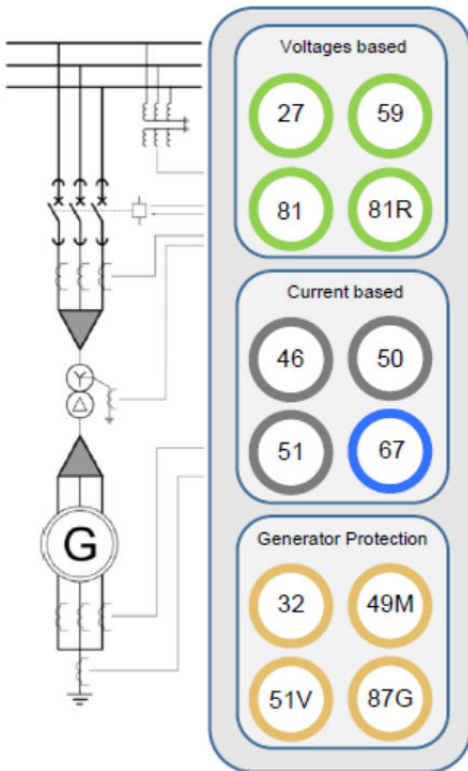

Transformer protection wiring (T257)

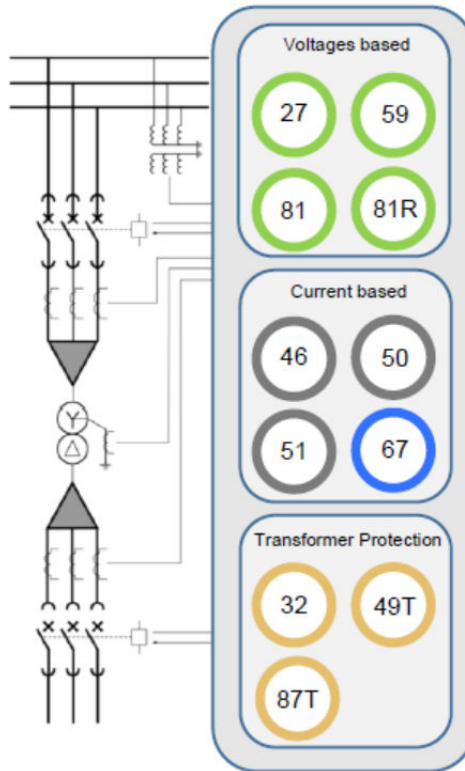

### Motor protection wiring (M215)

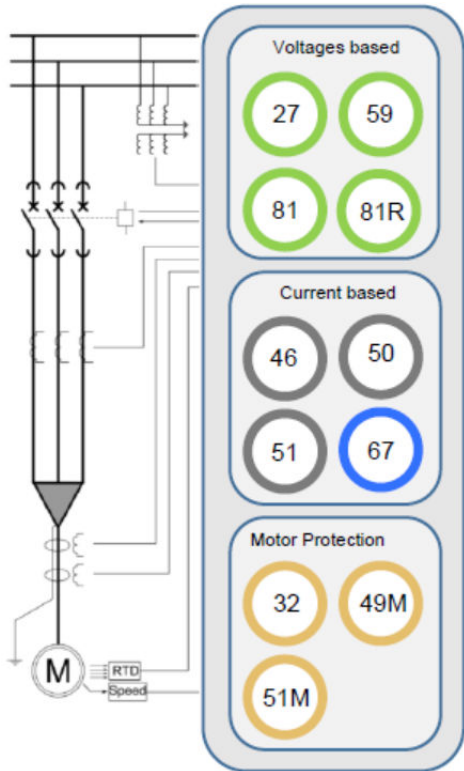

### Feeder protection wiring (F215)

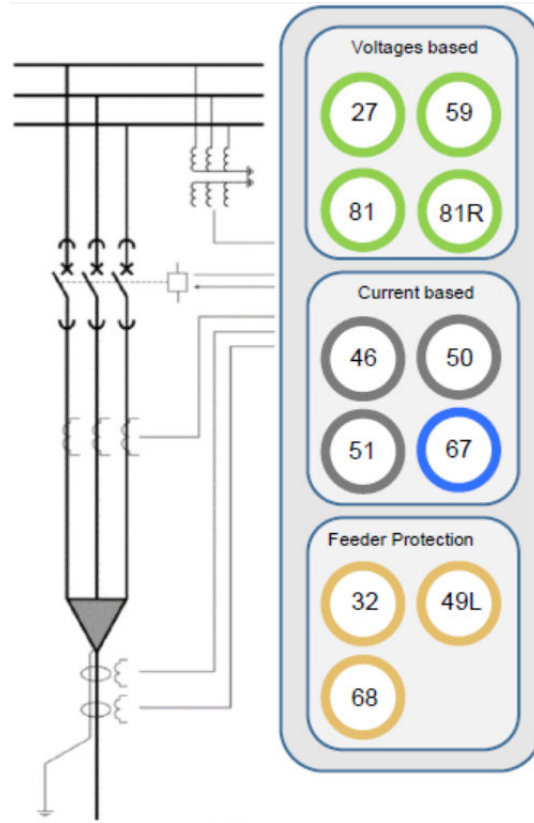

## 1.3 Features

	Functions
Full product range, high performance, good usability	<ul style="list-style-type: none"> <li>• Full protection for lines, feeders, motors, generators and transformers</li> <li>• Bay control, alarm, measurement and monitoring</li> <li>• Large customisable HMI with configurable Mimic diagram</li> <li>• Freely configurable alarm LEDs and function buttons</li> <li>• Large flash memory for events, logs, recordings and documentation                             <ul style="list-style-type: none"> <li>◦ 15,000 events and 100 disturbance recordings</li> </ul> </li> <li>• Easy-to-use and powerful MVR Utility Software for setting, configuration and analysing</li> <li>• Wizards for setting calculations</li> <li>• Full set of communication protocols, including IEC 61850</li> </ul>
Versatile protection design	<ul style="list-style-type: none"> <li>• Fast, versatile and dependable protection functions over a wide frequency range (6 to 75 Hz)</li> <li>• Suitable for the most demanding protection applications including rotating machines</li> </ul>
Modularity	<ul style="list-style-type: none"> <li>• Fully modular hardware construction</li> <li>• Plug in more I/O or communication cards to meet the application requirements</li> </ul>
Usability	<ul style="list-style-type: none"> <li>• Software wizards</li> <li>• Sophisticated setting aids</li> <li>• Highly customisable HMI</li> <li>• Storage of PDF or other supportive documents</li> <li>• Extensive user log information                             <ul style="list-style-type: none"> <li>◦ Setting changes</li> <li>◦ Other operational history</li> </ul> </li> </ul>
Performance	<ul style="list-style-type: none"> <li>• Sub-cycle instantaneous trip times</li> <li>• PLC programming is included, allowing for extensive customisation</li> </ul>

	Functions
	<ul style="list-style-type: none"> <li>• Up to 100 disturbance records, of up to 10 seconds each</li> <li>• 10,000 events stored in non-volatile memory</li> </ul>
Savings in engineering time	<ul style="list-style-type: none"> <li>• MVR Utility Software free-of-charge software suite with an intuitive and easy-to-use human-machine interface</li> <li>• Download all relay settings instantly using native 100 Mb/s Ethernet connection (front port or rear port)</li> </ul>
Standardised hardware	<ul style="list-style-type: none"> <li>• Standardised hardware design, for simpler logistics and stock management</li> <li>• Five CT inputs with configurable secondary currents</li> <li>• Configurable digital input voltage thresholds</li> </ul>
Communication	<ul style="list-style-type: none"> <li>• Native Ethernet communication</li> <li>• A variety of standard protocols including the IEC 61850 substation communication standard with fast GOOSE messaging</li> </ul>
IEC 61850 & IEEE 1588	<ul style="list-style-type: none"> <li>• High-availability Seamless Redundancy (HSR) support</li> <li>• Parallel Redundancy Protocol (PRP) support</li> <li>• Precision Time Protocol (PTP) according to IEEE 1588</li> </ul>



## 2. Protections

### 2.1 Current protections

#### 2.1.1 Non-directional over-current (50/51) I>, I>>, I>>>, I>>>>

Input signals	
Input magnitudes	Phase current fundamental frequency RMS Phase current TRMS Phase current peak-to-peak
Pick-up	
Pick-up current setting	0.10 to 50.00 x I <sub>n</sub> , setting step 0.0001 x I <sub>n</sub> 0.10 to 50.00 %I <sub>1f</sub> , setting step 0.01 %I <sub>1f</sub>
Inaccuracy • Current • 2nd harmonic	±0.5 %I <sub>SET</sub> or ±15 mA (0.10 to 4.0 x I <sub>SET</sub> ) ±1.0 %-unit of 2nd harmonic setting
Operation time	
Definite time function operating time setting	0.00 to 1800.00 s, setting step 0.005 s
Inaccuracy • Definite Time (I <sub>m</sub> /I <sub>set</sub> ratio > 3) • Definite Time (I <sub>m</sub> /I <sub>set</sub> ratio 1.05 to 3)	±1.0 % or ±20 ms ±1.0 % or ±30 ms
IDMT operating time setting (ANSI/IEC)	0.02 to 1800.00 s, setting step 0.001 x parameter
IDMT setting parameters	
k Time dial setting for IDMT	0.01 to 25.00 step 0.01
A IDMT Constant	0 to 250.0000 step 0.0001
B IDMT Constant	0 to 5.0000 step 0.0001
C IDMT Constant	0 to 250.0000 step 0.0001
Inaccuracy • IDMT operating time • IDMT minimum operating time; 20 ms	±1.5 % or ±20 ms ±20 ms
Retardation time (overshoot)	<25 ms
Instant operation time	
Start time and instant operation time (trip): (I <sub>m</sub> /I <sub>set</sub> ratio >3) (I <sub>m</sub> /I <sub>set</sub> ratio 1.05 to 3)	<35 ms (typically 25 ms) <50 ms
Reset	
Reset ratio	97 % of pick-up current setting
Reset time setting Inaccuracy: Reset time	0.010 to 10.000 s, step 0.005 s ±1.0 % or ±50 ms
Instant reset time and start-up reset	<50 ms

**NOTE** Release delay does not apply on phase-specific tripping.

#### 2.1.2 Non-directional earth fault (50N/51N) I0>, I0>>, I0>>>, I0>>>>

Input signals	
Input magnitudes	Residual current fundamental frequency RMS



	Residual current TRMS Residual current peak-to-peak
<b>Pick-up</b>	
Used magnitude	Measured residual current I01 (1 A) Measured residual current I02 (0.2 A) Calculated residual current I0Calc (5 A)
Pick-up current setting	0.0001 to 40.00 x I <sub>n</sub> , setting step 0.0001 x I <sub>n</sub>
Inaccuracy • Starting I01 (1 A) • Starting I02 (0.2 A) • Starting I0Calc (5 A)	±0.5 % I <sub>0SET</sub> or ±3 mA (0.005 to 10.0 x I <sub>SET</sub> ) ±1.5 % I <sub>0SET</sub> or ±1.0 mA (0.005 to 25.0 x I <sub>SET</sub> ) ±1.0 % I <sub>0SET</sub> or ±15 mA (0.005 to 4.0 x I <sub>SET</sub> )
<b>Operating time</b>	
Definite time function operating time setting	0.00 to 1800.00 s, setting step 0.005 s
Inaccuracy • Definite Time (I <sub>m</sub> /I <sub>set</sub> ratio >3) • Definite Time (I <sub>m</sub> /I <sub>set</sub> ratio 1.05 to 3)	±1.0 % or ±20 ms ±1.0 % or ±30 ms
IDMT operating time setting (ANSI / IEC)	0.02 to 1800.00 s, setting step 0.001 x parameter
IDMT setting parameters k Time dial setting for IDMT A IDMT Constant B IDMT Constant C IDMT Constant	0.01 to 25.00 step 0.01 0 to 250.0000 step 0.0001 0 to 5.0000 step 0.0001 0 to 250.0000 step 0.0001
Inaccuracy • IDMT operating time • IDMT minimum operating time; 20 ms	±1.5 % or ±20 ms ±20 ms
Retardation time (overshoot)	<25 ms
<b>Instant operation time</b>	
Start time and instant operation time (trip): (I <sub>m</sub> /I <sub>set</sub> ratio >3.5) (I <sub>m</sub> /I <sub>set</sub> ratio 1.05 to 3.5)	<50 ms (typical 35 ms) <55 ms
<b>Reset</b>	
Reset ratio	97 % of pick-up current setting
Reset time setting Inaccuracy: Reset time	0.010 to 10.000 s, step 0.005 s ±1.0 % or ±50 ms
Instant reset time and start-up reset	<50 ms

**NOTE** Operation and reset time accuracy do not apply for 1 to 20 mA measured primary current when the I02 channel is used. The pick-up is more sensitive, and so operation times can vary.

### 2.1.3 Directional over-current (67) IDIR>, IDIR>>, IDIR>>>, IDIR>>>>

<b>Input signals</b>	
Input magnitudes	Phase current fundamental frequency RMS Phase current TRMS Phase current peak-to-peak P-P +U <sub>0</sub> voltage fundamental frequency RMS P-E voltage fundamental frequency RMS
<b>Pick-up</b>	

Characteristic direction	Directional, Non-directional
Operating sector center	-180.0 to 180.0°, setting step 0.1°
Operating sector size (±)	1.00 to 170.00°, setting step 0.10°
Pick-up current setting	0.10 to 40.00 x I <sub>n</sub> , setting step 0.01 x I <sub>n</sub>
Inaccuracy	
• Current	±0.5 % I <sub>SET</sub> or ±15 mA (0.10 to 4.0 x I <sub>SET</sub> )
• U1/I1 angle (U > 15 V)	±0.20°
• U1/I1 angle (U = 1 to 15 V)	±1.5°
<b>Operation time</b>	
Definite time function operating time setting	0.00 to 1800.00 s, setting step 0.005 s
Inaccuracy	
• Definite Time (I <sub>m</sub> /I <sub>set</sub> ratio > 3)	±1.0 % or ±20 ms
• Definite Time (I <sub>m</sub> /I <sub>set</sub> ratio 1.05 to 3)	±1.0 % or ±35 ms
IDMT operating time setting (ANSI/IEC)	0.02 to 1800.00 s, setting step 0.001 x parameter
IDMT setting parameters	
k Time dial setting for IDMT	0.01 to 25.00 step 0.01
A IDMT Constant	0 to 250.0000 step 0.0001
B IDMT Constant	0 to 5.0000 step 0.0001
C IDMT Constant	0 to 250.0000 step 0.0001
Inaccuracy	
• IDMT operating time	±1.5 % or ±20 ms
• IDMT minimum operating time; 20 ms	±20 ms
<b>Instant operation time</b>	
Start time and instant operation time (trip):	
(I <sub>m</sub> /I <sub>set</sub> ratio >3)	<40 ms (typical 30 ms)
(I <sub>m</sub> /I <sub>set</sub> ratio 1.05 to 3)	<50 ms
<b>Reset</b>	
Reset ratio	
• Current	97 % of pick-up current setting
• U1/I1 angle	2.0°
Reset time setting	0.010 to 10.000 s, step 0.005 s
Inaccuracy: Reset time	±1.0 % or ±50 ms
Instant reset time and start-up reset	<50 ms

**NOTE** The minimum voltage for direction solving is 1.0 V secondary. During three-phase short circuits, the angle memory is active for 0.5 seconds in case the voltage drops below 1.0 V.

## 2.1.4 Directional earth fault (67N) I0DIR>, I0DIR>>, I0DIR>>>, I0DIR>>>>

<b>Input signals</b>	
Input current magnitudes	Residual current fundamental frequency RMS Residual current TRMS Residual current peak-to-peak
Input voltage magnitude	Zero sequence voltage fundamental frequency RMS
<b>Pick-up</b>	
Used current magnitude	Measured residual current I01 (1 A) Measured residual current I02 (0.2 A) Calculated residual current I0Calc (5 A)

Used voltage magnitude	Measured zero sequence voltage U <sub>0</sub> Calculated zero sequence voltage U <sub>0</sub>
Characteristic direction	Unearthed (Varmetric 90°) Petersen coil GND (Wattmetric 180°) <u>Grounded</u> (Adjustable sector)
When <u>grounded</u> mode is active: • Trip area center • Trip area size (±)	0.00 to 360.00°, setting step 0.10° 45.00 to 135.00°, setting step 0.10°
Pick-up current setting Pick-up voltage setting	0.005 to 40.00 x I <sub>n</sub> , setting step 0.001 x I <sub>n</sub> 1.00 to 50.00 % U <sub>0n</sub> , setting step 0.01 x I <sub>n</sub>
Inaccuracy: Starting I <sub>01</sub> (1 A) Starting I <sub>02</sub> (0.2 A) Starting I <sub>0Calc</sub> (5 A) Voltage U <sub>0</sub> and U <sub>0Calc</sub> U <sub>0</sub> /I <sub>0</sub> angle (U > 15 V) U <sub>0</sub> /I <sub>0</sub> angle (U = 1 to 15 V)	±0.5 % I <sub>0SET</sub> or ±3 mA (0.005 to 10.0 x I <sub>SET</sub> ) ±1.5 % I <sub>0SET</sub> or ±1.0 mA (0.005 to 25.0 x I <sub>SET</sub> ) ±1.5 % I <sub>0SET</sub> or ±15 mA (0.005 to 4.0 x I <sub>SET</sub> ) ±2.5 % U <sub>0SET</sub> ±0.2° (I <sub>0Calc</sub> ±1.0°) ±1.0°
<b>Operation time</b>	
Definite time function operating time setting	0.00 to 1800.00 s, setting step 0.005 s
Inaccuracy Definite Time (I <sub>m</sub> /I <sub>set</sub> ratio 1.05→)	±1.0 % or ±45 ms
IDMT operating time setting (ANSI/IEC)	0.02 to 1800.00 s, setting step 0.001 x parameter
IDMT setting parameters k Time dial setting for IDMT A IDMT Constant B IDMT Constant C IDMT Constant	0.01 to 25.00 step 0.01 0 to 250.0000 step 0.0001 0 to 5.0000 step 0.0001 0 to 250.0000 step 0.0001
Inaccuracy IDMT operating time IDMT minimum operating time; 20 ms	±1.5 % or ±20 ms ±20 ms
<b>Instant operation time</b>	
Start time and instant operation time (trip): (I <sub>m</sub> /I <sub>set</sub> ratio > 3) (I <sub>m</sub> /I <sub>set</sub> ratio 1.05 to 3)	<55 ms (typical 45 ms) <65 ms
<b>Reset</b>	
Current and voltage reset U <sub>0</sub> /I <sub>0</sub> angle	97 % of pick-up current and voltage setting 2.0°
Reset time setting Inaccuracy: Reset time	0.000 to 150.000 s, step 0.005 s ±1.0 % or ±45 ms
Instant reset time and start-up reset	<50 ms

## 2.1.5 Current unbalance (46/46R/46L) I<sub>2></sub>, I<sub>2>></sub>, I<sub>2>>></sub>, I<sub>2>>>></sub>

<b>Input signals</b>	
Input magnitudes	Phase current fundamental frequency RMS
<b>Pick-up</b>	
Used magnitude	Negative sequence component I <sub>2pu</sub> Relative unbalance I <sub>2</sub> /I <sub>1</sub>
Pick-up setting	0.01 to 40.00 x I <sub>n</sub> , setting step 0.01 x I <sub>n</sub> (I <sub>2pu</sub> )

	1.00 to 200.00 %, setting step 0.01 % (I2/I1)
Minimum phase current (least 1 phase above)	0.01 to 2.00 x I <sub>n</sub> , setting step 0.01 x I <sub>n</sub>
Inaccuracy • Starting I <sub>2pu</sub> • Starting I <sub>2/I1</sub>	±1.0 %-unit or ±100 mA (0.10 to 4.0 x I <sub>N</sub> ) ±1.0 %-unit or ±150 mA (0.10 to 4.0 x I <sub>N</sub> )
<b>Operating time</b>	
Definite time function operating time setting	0.00 to 1800.00 s, setting step 0.005 s
Inaccuracy • Definite Time (I <sub>m</sub> /I <sub>set</sub> ratio >1.05)	±1.5 % or ±60 ms
IDMT operating time setting (ANSI/IEC)	0.02 to 1800.00 s, setting step 0.001 x parameter
IDMT setting parameters	
k Time dial setting for IDMT	0.01 to 25.00 step 0.01
A IDMT Constant	0 to 250.0000 step 0.0001
B IDMT Constant	0 to 5.0000 step 0.0001
C IDMT Constant	0 to 250.0000 step 0.0001
Inaccuracy • IDMT operating time • IDMT minimum operating time; 20 ms	±1.5 % or ±20 ms ±20 ms
Retardation time (overshoot)	<5 ms
<b>Instant operation time</b>	
Start time and instant operation time (trip): (I <sub>m</sub> /I <sub>set</sub> ratio >1.05)	<70 ms
<b>Reset</b>	
Reset ratio	97 % of pick-up setting
Reset time setting Inaccuracy: Reset time	0.010 to 10.000 s, step 0.005 s ±1.5 % or ±60 ms
Instant reset time and start-up reset	<55 ms

## 2.1.6 Circuit breaker failure protection (50BF/52BF) CBFP

<b>Input signals</b>	
Input magnitudes	Phase currents, I01, I02 I0Calc fundamental frequency RMS Digital input status, Digital output status
<b>Pick-up</b>	
Pick-up current setting • IL1 to IL3 • I01, I02, I0Calc	0.10 to 40.00 x I <sub>n</sub> , setting step 0.01 x I <sub>n</sub> 0.005 to 40.00 x I <sub>n</sub> , setting step 0.005 x I <sub>n</sub>
Inaccuracy Starting phase current (5 A) Starting I01 (1 A) Starting I02 (0.2 A) Starting I0Calc (5 A)	±0.5 % I <sub>SET</sub> or ±15 mA (0.10 to 4.0 x I <sub>SET</sub> ) ±0.5 % I <sub>0SET</sub> or ±3 mA (0.005 to 10.0 x I <sub>SET</sub> ) ±1.5 % I <sub>0SET</sub> or ±1.0 mA (0.005 to 25.0 x I <sub>SET</sub> ) ±1.0 % I <sub>0SET</sub> or ±15 mA (0.005 to 4.0 x I <sub>SET</sub> )
<b>Operation time</b>	
Definite time function operating time setting	0.050 to 1800.000 s, setting step 0.005 s
Inaccuracy • Current criteria (I <sub>m</sub> /I <sub>set</sub> ratio 1.05→) • DO or DI only	±1.0 % or ±55 ms ±15 ms

<b>Reset</b>	
Reset ratio	97 % of pick-up current setting
Reset time	<50 ms

## 2.1.7 Restricted earth fault/cable end differential (87N) I0D>

<b>Input signals</b>	
Input magnitudes	Phase currents, I01, I02 fundamental frequency RMS Calculated bias and residual differential currents
<b>Pick-up</b>	
Operating modes	Restricted earth fault Cable end differential
Characteristics	Biased differential with 3 settable sections and 2 slopes
Pick-up current sensitivity setting	0.01 to 50.00 % (In), setting step 0.01 %
Slope 1	0.00 to 150.00 %, setting step 0.01 %
Slope 2	0.00 to 250.00 %, setting step 0.01 %
BIAS (Slope 1&2)	0.01 to 50.00 x In, setting step 0.01
Inaccuracy - Starting	±3 % of set pick-up value > 0.5 x In setting. ±5 mA < 0.5 x In setting
<b>Operation time</b>	
Instant operation time - 1.05 x Iset	<30 ms
<b>Reset</b>	
Reset ratio	No hysteresis
Reset time	<40 ms

## 2.1.8 Harmonic over-current (50H/51H, 68) IH>, IH>>, IH>>>, IH>>>>

<b>Input signals</b>	
Input magnitudes	Phase current IL1/IL2/IL3 TRMS Residual current I01 TRMS Residual current I02 TRMS
<b>Pick-up</b>	
Harmonic selection	2nd, 3rd, 4th, 5th, 7th, 9th, 11th, 13th, 15th, 17th or 19th
Used magnitude	Harmonic per unit x In Harmonic relative Ih/IL
Pick-up setting	0.05 to 2.00 x In, setting step 0.01 x In (x In) 5.00 to 200.00 %, setting step 0.01 % (Ih/IL)
Inaccuracy	
• Starting x In	<0.03 x In (2nd, 3rd, 5th)
• Starting x Ih/IL	<0.03 x In tolerance to Ih (2nd, 3rd, 5th)
<b>Operation time</b>	
Definite time function operating time setting	0.00 to 1800.00 s, setting step 0.005 s
Inaccuracy - Definite Time (Im/Iset ratio >1.05)	±1.0 % or ±35 ms
IDMT operating time setting (ANSI / IEC)	0.02 to 1800.00 s, setting step 0.001 x parameter
IDMT setting parameters	0.01 to 25.00 step 0.01
k Time dial setting for IDMT	0 to 250.0000 step 0.0001
A IDMT Constant	0 to 5.0000 step 0.0001

B IDMT Constant	
C IDMT Constant	0 to 250.0000 step 0.0001
Inaccuracy	
• IDMT operating time	±1.5 % or ±20 ms
• IDMT minimum operating time; 20 ms	±20 ms
<b>Instant operation time</b>	
Start time and instant operation time (trip): (Im/Iset ratio >1.05)	<50 ms
<b>Reset</b>	
Reset ratio	95 % of pick-up setting
Reset time setting	0.010 to 10.000 s, step 0.005 s
Inaccuracy: Reset time	±1.0 % or ±35 ms
Instant reset time and start-up reset	<50 ms

- NOTE**
- Harmonics generally: Amplitude of harmonic content has to be least 0.02 x In when relative (Ih/IL) mode is used.
  - Blocking: To achieve fast activation for blocking purpose with harmonic OC stage the harmonic stage may activate if rapid load change or fault situation occur. Intentional activation lasts for about 20 ms if harmonic component is not present. Harmonic stage stays active in case the harmonic content is above the pick-up limit.
  - Tripping: When using a harmonic OC stage for tripping make sure that the operation time is set to 20 ms (DT) or higher to avoid nuisance tripping due the above mentioned reason.

## 2.2 Voltage protections

### 2.2.1 Under-voltage (27) U<, U<<, U<<<, U<<<<

<b>Input signals</b>	
Input magnitudes	P-P voltage fundamental frequency RMS P-E voltage fundamental frequency RMS
<b>Pick-up</b>	
Pick-up terms	1 voltage 2 voltages 3 voltages
Pick-up setting	0.00 to 120.00 % Un, setting step 0.01 % Un
Inaccuracy - Voltage	±1.5 % U <sub>SET</sub> or ±30 mV
<b>Low voltage block</b>	
Pick-up setting	0.00 to 80.00 % Un, setting step 0.01 % Un
Inaccuracy - Voltage	±1.5 % U <sub>SET</sub> or ±30 mV
<b>Operation time</b>	
Definite time function operating time setting	0.00 to 1800.00 s, setting step 0.005 s
Inaccuracy - Definite Time (Um/Uset ratio 1.05→)	±1.0 % or ±35 ms
IDMT operating time setting (ANSI / IEC)	0.02 to 1800.00 s, setting step 0.001 x parameter
IDMT setting parameters	
k Time dial setting for IDMT	0.01 to 25.00 step 0.01
A IDMT Constant	0 to 250.0000 step 0.0001
B IDMT Constant	0 to 5.0000 step 0.0001
C IDMT Constant	0 to 250.0000 step 0.0001
Inaccuracy	
• IDMT operating time	±1.5 % or ±20 ms
• IDMT minimum operating time; 20 ms	±20 ms

<b>Instant operation time</b>	
Start time and instant operation time (trip): Um/Uset ratio 1.05→	<65 ms
Retardation time (overshoot)	<30 ms
<b>Reset</b>	
Reset ratio	103 % of pick-up voltage setting
Reset time setting Inaccuracy: Reset time	0.010 to 10.000 s, step 0.005 s ±1.0 % or ±45 ms
Instant reset time and start-up reset	<50 ms

- NOTE**
- LV block is not in use when set to 0 %. Under-voltage is on trip stage if LV block is disabled and IED is without voltage injection.
  - After blocking condition, under voltage stage will not trip unless voltage is higher than pick-up setting first.

## 2.2.2 Over-voltage (59) U>, U>>, U>>>, U>>>>

<b>Input signals</b>	
Input magnitudes	P-P voltage fundamental frequency RMS P-E voltage fundamental frequency RMS
<b>Pick-up</b>	
Pick-up terms	1 voltage 2 voltages 3 voltages
Pick-up setting	50.00 to 150.00 % Un, setting step 0.01 % Un
Inaccuracy - Voltage	±1.5 % U <sub>SET</sub>
<b>Operating time</b>	
Definite time function operating time setting	0.00 to 1800.00 s, setting step 0.005 s
Inaccuracy - Definite Time (Um/Uset ratio 1.05→)	±1.0 % or ±35 ms
IDMT operating time setting (ANSI / IEC)	0.02 to 1800.00 s, setting step 0.001 x parameter
IDMT setting parameters	
k Time dial setting for IDMT	0.01 to 25.00 step 0.01
A IDMT Constant	0 to 250.0000 step 0.0001
B IDMT Constant	0 to 5.0000 step 0.0001
C IDMT Constant	0 to 250.0000 step 0.0001
Inaccuracy	
• IDMT operating time	±1.5 % or ±20 ms
• IDMT minimum operating time; 20 ms	±20 ms
<b>Instant operation time</b>	
Start time and instant operation time (trip): Um/Uset ratio 1.05→	<50 ms
<b>Reset</b>	
Reset ratio	97 % of pick-up voltage setting
Reset time setting Inaccuracy: Reset time	0.010 to 10.000 s, step 0.005 s ±1.0 % or ±45 ms
Instant reset time and start-up reset	<50 ms



## 2.2.3 Neutral over-voltage (59N) U0>, U0>>, U0>>>, U0>>>>

Input signals	
Input magnitudes	U0 voltage fundamental frequency RMS
Pick-up	
Pick-up voltage setting	1.00 to 50.00 % U0n, setting step 0.01 x In
Inaccuracy • Voltage U0 • Voltage U0Calc	±1.5 % U0SET or ±30 mV ±150 mV
Operation time	
Definite time function operating time setting	0.00 to 1800.00 s, setting step 0.005 s
Inaccuracy - Definite Time (U0m/U0set ratio 1.05→)	±1.0 % or ±45 ms
IDMT operating time setting (ANSI / IEC)	0.02 to 1800.00 s, setting step 0.001 x parameter
IDMT setting parameters	
k Time dial setting for IDMT	0.01 to 25.00 step 0.01
A IDMT Constant	0 to 250.0000 step 0.0001
B IDMT Constant	0 to 5.0000 step 0.0001
C IDMT Constant	0 to 250.0000 step 0.0001
Inaccuracy • IDMT operating time • IDMT minimum operating time; 20 ms	±1.5 % or ±20 ms ±20 ms
Instant operation time	
Start time and instant operation time (trip): U0m/U0set ratio 1.05→	<50 ms
Reset	
Reset ratio	97 % of pick-up voltage setting
Reset time setting Inaccuracy: Reset time	0.000 to 150.000 s, step 0.005 s ±1.0 % or ±50 ms
Instant reset time and start-up reset	<50 ms

## 2.2.4 Sequence voltage (47/27PN/59PN) U1/2>/< (1 to 4)

Input signals	
Input magnitudes	P-E voltage fundamental frequency RMS P-P voltage fundamental frequency RMS + U0
Pick-up	
Pick-up setting	5.00 to 150.00 % Un, setting step 0.01 % Un
Inaccuracy - Voltage	±1.5 % USET or ±30 mV
Low voltage block	
Pick-up setting	1.00 to 80.00 % Un, setting step 0.01 % Un
Inaccuracy - Voltage	±1.5 % USET or ±30 mV
Operation time	
Definite time function operating time setting	0.00 to 1800.00 s, setting step 0.005 s
Inaccuracy - Definite Time (Um/Uset ratio 1.05→)	±1.0 % or ±35 ms
IDMT operating time setting (ANSI/IEC)	0.02 to 1800.00 s, setting step 0.001 x parameter
IDMT setting parameters	0.01 to 25.00 step 0.01

k	Time dial setting for IDMT	
A	IDMT Constant	0 to 250.0000 step 0.0001
B	IDMT Constant	0 to 5.0000 step 0.0001
C	IDMT Constant	0 to 250.0000 step 0.0001
Inaccuracy		
• IDMT operating time		±1.5 % or ±20 ms
• IDMT minimum operating time; 20 ms		±20 ms
<b>Instant operation time</b>		
Start time and instant operation time (trip): -Um/Uset ratio 0.95/1.05→		<65 ms
<b>Reset</b>		
Reset ratio		97/103 % of pick-up voltage setting
Reset time setting		0.010 to 10.000 s, step 0.005 s
Inaccuracy: Reset time		±1.0 % or ±35 ms
Instant reset time and start-up reset		<50 ms

## 2.2.5 Vector jump (78) ΔA>

<b>Input signals</b>	
Input magnitudes	P-P voltage fundamental frequency RMS P-E voltage fundamental frequency RMS
Monitored voltages	System any or all P-P voltage(s) System any or all P-E voltage(s) Chosen specific P-P or P-E voltage U4 voltage
<b>Pick-up</b>	
Pick-up Δα setting	1.00 to 30.00°, setting step 0.01°
Inaccuracy - Voltage angle	±0.15°
<b>Low voltage block</b>	
Pick-up setting	50.00 to 100.00 % Un, setting step 0.01 % Un
Inaccuracy - Voltage	±1.5 % U <sub>SET</sub> or ±30 mV
<b>Instant operation time</b>	
Alarm and trip operation time: (Im/Iset ratio > ±0.15° to pick-up)	<20 ms (typical 15 ms)
<b>Reset</b>	
Reset ratio - Voltage angle	2.0°
Alarm and trip reset time	<50 ms

## 2.3 Frequency protections

### 2.3.1 Over- or under-frequency (81O/81U) F>/<, F>>/<<, F>>>/<<<, F>>>>/<<<<

<b>Input signals</b>	
Sampling mode	Fixed Tracking
Frequency reference1	CT11L1, CT21L1, VT1U1, VT2U1
Frequency reference2	CT11L2, CT21L2, VT1U2, VT2U2
Frequency reference3	CT11L3, CT21L3, VT1U3, VT2U3

<b>Pick-up</b>	
f> pick-up setting	10.00 to 70.00 Hz, setting step 0.01 Hz
f< pick-up setting	7.00 to 65.00 Hz, setting step 0.01 Hz
Inaccuracy (sampling mode)	
• Fixed	±20 mHz (50/60 Hz fixed frequency)
• Tracking	±20 mHz (U > 30 V secondary) ±20 mHz (I > 30 % of rated secondary)
<b>Operation time</b>	
Definite time function operating time setting	0.00 to 1800.00 s, setting step 0.005 s
Inaccuracy - Definite Time (Im/Iset ratio ±50 mHz)	±1.5 % or ±50 ms (max. step size 100 mHz)
<b>Instant operation time</b>	
Start time and instant operation time (trip):	
(Im/Iset ratio ±50 mHz) FIXED mode	<70 ms (max. step size 100 mHz)
(Im/Iset ratio ±50 mHz) TRACKING mode	<3 cycles or <60 ms (max. step size 100 mHz)
<b>Reset</b>	
Reset ratio	0.020 Hz
Instant reset time and start-up reset	
(Im/Iset ratio ±50 mHz) FIXED mode	<110 ms (max. step size 100 mHz)
(Im/Iset ratio ±50 mHz) TRACKING mode	<3 cycles or <70 ms (max. step size 100 mHz)

- NOTE**
- Secondary voltage must be higher than 2 volts or current higher than 0.25 amperes (peak-to peak) to measure frequency.
  - Frequency is measured in 2 seconds after a signal is received.
  - Fixed frequency mode: When fixed mode is used, the system nominal frequency should be set to 50 or 60 Hz.
  - Tracked frequency mode: When tracked mode is used the system nominal frequency can be anything from 7 to 75 Hz.

### 2.3.2 Rate of change of frequency (81R) df/dt >/< (1 to 8)

<b>Input signals</b>	
Sampling mode	Fixed Tracking
Frequency reference1	CT1IL1, CT2IL1, VT1U1, VT2U1
Frequency reference2	CT1IL2, CT2IL2, VT1U2, VT2U2
Frequency reference3	CT1IL3, CT2IL3, VT1U3, VT2U3
<b>Pick-up</b>	
Df/dt>/< pick-up setting	0.15 to 1.00 Hz/s, setting step 0.01 Hz
f> limit	10.00 to 70.00 Hz, setting step 0.01 Hz
f< limit	7.00 to 65.00 Hz, setting step 0.01 Hz
Inaccuracy	
• df/dt	±5.0 % I <sub>SET</sub> or ±20 mHz/s
• frequency	±15 mHz (U > 30 V secondary) ±20 mHz (I > 30 % of rated secondary)
<b>Operation time</b>	
Definite time function operating time setting	0.00 to 1800.00 s, setting step 0.005 s
Inaccuracy - Definite Time (Im/Iset ratio ±50 mHz)	±1.5 % or ±110 ms (max. step size 100 mHz)
<b>Instant operation time</b>	
Start time and instant operation time (trip):	<200 ms
• (fm/fset ratio ±20 mHz overreach)	<90 ms

•(fm/fset ratio $\pm 200$ mHz overreach)	
<b>Reset</b>	
Reset ratio (Frequency limit) df/dt	0.020 Hz 0.100 Hz/s of pick-up or 0.100 Hz/s absolute at low end
Instant reset time and start-up reset - (fm/fset ratio $\pm 50$ mHz)	<325 ms (max. step size 100 mHz)

**NOTE** Frequency is measured 2 seconds after a signal is received.

## 2.4 Power protections

### 2.4.1 Over-, under- and reverse power (32/37) P>, P<, PREV>

<b>Input signals</b>	
Input magnitudes	Phase current and voltage fundamental frequency RMS
<b>Pick-up</b>	
P> P <sub>REV&gt;</sub>	0.10 to 150000.00 kW, setting step 0.01 kW -15000.00 to -1.00 kW, setting step 0.01 kW
P< Low Power block Pset<	0.00 to 150000.00 kW, setting step 0.01 kW 0.00 to 100000.00 kW, setting step 0.01 kW
Inaccuracy - Active power	Typically <1.0 % P <sub>SET</sub>
<b>Operation time</b>	
Definite time function operating time setting	0.00 to 1800.00 s, setting step 0.005 s
Inaccuracy - Definite Time (Pm/Pset ratio 1.05→)	$\pm 1.0$ % or $\pm 35$ ms
<b>Instant operation time</b>	
Start time and instant operation time (trip): (Pm/Pset ratio 1.05→)	<50 ms
<b>Reset</b>	
Reset ratio	0.97/1.03 x Pset
Reset time setting Inaccuracy: Reset time	0.000 to 150.000 s, step 0.005 s $\pm 1.0$ % or $\pm 35$ ms
Instant reset time and start-up reset	<50 ms

- NOTE**
- Voltage measurement starts from 0.5 V and current measurement from 50 mA. In case either or both is missing the power measurement is forced to 0 kW. In case the settings allow (low power block = 0 kW), the P< might be on trip state during this condition. Trip is released when voltage and current is started to measure.
  - When low power block is set to zero it is not in use. Also power measurement below 1.00 kW is forced to zero (P< blocked).

### 2.4.2 Active, reactive and apparent power (32/37) PQS>/< (1 to 4)

<b>Input signals</b>	
Input magnitudes	Phase current and voltage fundamental frequency RMS
Magnitude selection	P, Q or S value based on chosen/set nominal amplitude
Comparator selection	> or <
<b>Pick-up</b>	
> or <	-500.000 to 500.000 %/MVAn, setting step 0.005 %/MVAn
Inaccuracy -Active/Reactive/Apparent power	Typically <1.0 % P <sub>SET</sub>

<b>Operation time</b>	
Definite time function operating time setting	0.00 to 1800.00 s, setting step 0.005 s
Inaccuracy -Definite Time (Pm/Pset ratio 1.05→)	±1.0 % or ±35 ms
<b>Instant operation time</b>	
Start time and instant operation time (trip): (PQSm/PQSset ratio 1.05→)	<40 ms
<b>Reset</b>	
Reset ratio	0.97/1.03 x Pset
Instant reset time and start-up reset	<40 ms

**NOTE** Voltage measurement starts from 0.5 V and current measurement from 25 mA. In case either or both is missing the measured magnitude is forced to 0 MW/MVar/MVA. Avoid using setting that should operate below relay current squelch limit (25 mA on relay terminal).

## 2.5 Feeder protections

### 2.5.1 Line thermal overload (49L) TF>

<b>Inputs</b>	
Input current magnitude	Phase current TRMS max. (31 harmonic)
<b>Settings</b>	
Time constants $\tau$	1
Time constant value	0.0 to 500.00 min by step of 0.1 min
Service factor (max. overloading)	0.01 to 5.00 by step of 0.01 x In
Thermal model biasing	<ul style="list-style-type: none"> <li>Ambient temperature (Set -60.0 to 500.0 ° by step of 0.1 °)</li> <li>Negative sequence current</li> </ul>
Thermal replica temperature estimates	Selectable °C or °F
<b>Outputs</b>	
Alarm 1	0 to 150 % by step of 1 %
Alarm 2	0 to 150 % by step of 1 %
Thermal Trip	0 to 150 % by step of 1 %
Trip delay	0.000 to 3600.000 s by step of 0.005 s
Restart Inhibit	0 to 150 % by step of 1 %
<b>Inaccuracy</b>	
Starting	±0.5 % of set pick-up value
Operating time	±5 % or ± 500 ms

### 2.5.2 Intermittent earth fault (67NT) I0INT>

<b>Input signals</b>	
Input current magnitudes	Residual current samples
Input voltage magnitude	Zero sequence voltage samples
<b>Pick-up settings</b>	
Used current magnitude	Measured residual current I01 (1 A) Measured residual current I02 (0.2 A)
Used voltage magnitude	Measured zero sequence voltage U0

Spikes to trip	1 to 50, setting step 1
Pick-up current setting	0.05 to 40.00 x I <sub>n</sub> , setting step 0.001 x I <sub>n</sub>
Pick-up voltage setting	1.00 to 100.00 % U <sub>0n</sub> , setting step 0.01 x I <sub>n</sub>
<b>Pick-up inaccuracy</b>	
Starting I01 (1 A)	±0.5 % I <sub>0SET</sub> or ±3 mA (0.005 to 10.0 x I <sub>SET</sub> )
Starting I02 (0.2 A)	±1.5 % I <sub>0SET</sub> or ±1.0 mA (0.005 to 25.0 x I <sub>SET</sub> )
Voltage U0	±1.0 % U <sub>0SET</sub> or ±30 mV
<b>Operation time setting</b>	
Definite time function operating time setting	0.00 to 1800.00 s, setting step 0.005 s
<b>Operation time inaccuracy</b>	
Definite Time (I <sub>m</sub> /I <sub>set</sub> ratio 1.05→)	±1.0 % or ±30 ms
<b>Instant operation time</b>	
Start time and instant operation time (trip): (I <sub>m</sub> /I <sub>set</sub> ratio 1.05→)	<15 ms
<b>Reset time</b>	
Reset time setting (FWD and REV)	0.000 to 1800.000 s, step 0.005 s
Inaccuracy: Reset time	±1.0 % or ±35 ms
Instant reset time and start-up reset	<50 ms

### 2.5.3 Auto-reclosing function (79) 0 → 1

<b>Input signals</b>	
Input signals	Software signals (Protection, Logics, etc.) Binary inputs
<b>Requests</b>	
REQ1-5	5 priority request inputs, possibility to set parallel signals to each request
<b>Shots</b>	
1-5 shots	5 independently –or scheme controlled shots in each AR request
<b>Operation time</b>	
Operating time setting • Lockout after successful AR • Object close reclaim time • AR shot starting delay • AR shot dead time delay • AR shot action time • AR shot specific reclaim time	0.00 to 1800.00 s, setting step 0.005 s
<b>Inaccuracy</b>	
AR starting (From start signal of protection)	±1.0 % or ±30 ms (AR delay)
AR starting (From trip signal of protection)	Trip delay inaccuracy +25 ms (Protection + AR delay)
Dead time	±1.0 % or ±35 ms (AR delay)
Action time	±1.0 % or ±30 ms (AR delay)
<b>Instant starting time</b>	
Instant operation time:	Protection activation delay + 15 ms (Protection + AR delay)

## 2.5.4 Fault locator (21FL) X → km

Input signals	
Input magnitudes	Phase current fundamental frequency RMS
Pick-up	
Trigger current >	0.00 to 40.00 x I <sub>n</sub> , setting step 0.01 x I <sub>n</sub>
Inaccuracy - Triggering	±0.5 % I <sub>SET</sub> or ±15 mA (0.10 to 4.0 x I <sub>SET</sub> )
Reactance	
Reactance per kilometer	0.000 to 5.000 s, setting step 0.001 ohm/km
Inaccuracy - Reactance	±5.0 % (typically)
Operation (Triggering)	
Activation	From trip signal of any protection stage
Minimum operation time	Least 0.040 s stage operation time required

## 2.6 Machine protections

### 2.6.1 Machine differential (87M) ID>

Input signals	
Input magnitudes	Phase currents of HV/LV side. Fundamental residual current measurement for HV/LV REF protection. 2nd and 5th harmonic measurement.
Characteristic (Differential and REF)	
Differential calculation mode	Add or Subtract (CT direction)
Bias calculation mode	Average or maximum (Sensitivity)
I <sub>db</sub> > Pick-up	0.01 to 100.00 % by step of 0.01 %, Default 10.00 %
Turnpoint 1	0.01 to 50.00 x I <sub>n</sub> by step of 0.01 x I <sub>n</sub> , Default 1.00 x I <sub>n</sub>
Slope 1	0.01 to 250.00 % by step of 0.01 %, Default 10.00 %
Turnpoint 2	0.01 to 50.00xI <sub>n</sub> by step of 0.01 x I <sub>n</sub> , Default 3.00 x I <sub>n</sub>
Slope 2	0.01 to 250.00 % by step of 0.01 %, Default 200.00 %
I <sub>di</sub> > Pick-up	200.00 % to 1500.00 % by step of 0.01 %, Default 600.00 %
Internal harmonic blocking selection	None, 2nd harmonic, 5th harmonic, both.
2nd harmonic blocking Pick-up	0.01 to 50.00 % by step of 0.01 %, Default 15.00 %
5th harmonic blocking Pick-up	0.01 to 50.00 % by step of 0.01 %, Default 35.00 %
Inaccuracy - Differential current	±3.0 % I <sub>SET</sub> or ±75 mA (0.10 to 4.0 x I <sub>SET</sub> )
Instant operation time	
Instant operation time >1.05xI <sub>SET</sub>	<40 ms (Harmonic blocking active)
Instant operation time >3.00xI <sub>SET</sub>	<30 ms (Harmonic blocking active)
Reset	
Reset ratio: Differential current	97 % typically of differential current setting
Reset time	<50 ms

### 2.6.2 Machine thermal overload (49M) TM>

Input signals	
Input magnitudes	Phase current TRMS (up to 31st harmonic)



<b>Pick-up (Heating)</b>	
NPS bias factor (unbalance effect)	0.1 to 10.0, setting step 0.1
Pick-up current setting	0.00 to 40.00 x I <sub>n</sub> , setting step 0.01 x I <sub>n</sub>
Thermal alarm and trip level setting range	0.0 to 150.0 %, setting step 0.1 %
Motor service factor	0.01 to 5.00 x I <sub>n</sub> , setting step 0.01 x I <sub>n</sub>
Cold condition	
• Long heat T const (cold)	0.0 to 500.0 min, setting step 0.1 min
• Short heat T const (cold)	0.0 to 500.0 min, setting step 0.1 min
Hot condition	
• Long heat T const (hot)	0.0 to 500.0 min, setting step 0.1 min
• Short heat T const (hot)	0.0 to 500.0 min, setting step 0.1 min
• Hot condition theta limit (Cold → Hot spot)	0.00 to 100.00 %, setting step 0.01 %
<b>Reset (Cooling)</b>	
Reset ratio (pick-up and alarms)	99 %
Stop condition	
• Long cool T const (stop)	0.0 to 500.0 min, setting step 0.1 min
• Short cool T const (stop)	0.0 to 500.0 min, setting step 0.1 min
• Short cool T in use time	0.0 to 3000.0 min, setting step 0.1 min
Run condition - Long cool T const (stop)	0.0 to 500.0 min, setting step 0.1 min
<b>Operation time</b>	
Definite time function operating time setting	0.0 to 3600.0 s, setting step 0.1 s
Inaccuracy - Pick-up and reset	±1.0 % or ±500 ms
<b>Environmental settings</b>	
Thermal replica temperature estimates	Selectable °C or °F
Ambient temperature effect	Linear or manually set curve
• k minimum –and maximum range	0.01 to 5.00 x I <sub>n</sub> , setting step 0.01 x I <sub>n</sub>
• Ambient temp min. –and max. range	-60 to 500 °, setting step 1 °
Thermal model biasing (ambient) - Set ambient temperature	-60 to 500 °, setting step 1 °

## 2.6.3 Power factor (55) PF<

<b>Input signals</b>	
Input magnitudes	Phase current fundamental frequency RMS P-E or PP voltage fundamental frequency RMS
<b>Pick-up</b>	
Pick-up PF setting	0.00 to 0.99, setting step 0.01
Inaccuracy - PF (when U > 1.0 V and I > 0.1 A)	±0.001
<b>Operation time</b>	
Definite time function operating time setting	0.00 to 1800.00 s, setting step 0.005 s
Inaccuracy - Definite Time (Least 0.01 below setting)	±1.0 % or ±30 ms
<b>Instant operation time</b>	
Start time and instant operation time (trip): (Least 0.01 below setting)	<50 ms
<b>Reset</b>	
Reset ratio	1.03 of PF setting
Reset time	<50 ms

**NOTE** Minimum voltage for PF calculation is 1.0 V secondary and minimum current is 0.1 A secondary.

## 2.7 Motor protections

### 2.7.1 Loss of load (37) I<

Input signals	
Input magnitudes	Phase current fundamental frequency RMS
Pick-up	
Pick-up current setting	0.10 to 40.00 x I <sub>n</sub> , setting step 0.10 x I <sub>n</sub>
Starting inaccuracy	±3 % of set pick-up value > 0.5 x I <sub>n</sub> setting. 5 mA < 0.5 x I <sub>n</sub> setting
Operation time	
Definite time function operating time setting	0.00 to 150.00 s, setting step 0.005 s
Inaccuracy - Definite Time (I <sub>m</sub> /I <sub>set</sub> ratio 0.95)	±1.0 % or ±30 ms
Instant operation time	
Start time and instant operation time (trip): (I <sub>m</sub> /I <sub>set</sub> ratio 0.95)	<50 ms
Reset	
Reset ratio	103 % of pick-up current setting
Reset time setting Inaccuracy: Reset time	0.010 to 150.000 s, step 0.005 s ±1.0 % or ±35 ms
Instant reset time and start-up reset	<50 ms

### 2.7.2 Mechanical jam (51M) I<sub>m</sub>>

Input signals	
Input magnitudes	Phase current fundamental frequency RMS
Pick-up	
Pick-up current setting	0.10 to 40.00 x I <sub>n</sub> , setting step 0.10 x I <sub>n</sub>
Inaccuracy - Current	±3 % of set pick-up value > 0.5 x I <sub>n</sub> setting. 5 mA < 0.5 x I <sub>n</sub> setting
Operation time	
Definite time function operating time setting	0.00 to 1800.00 s, setting step 0.005 s
Inaccuracy - Definite Time (I <sub>m</sub> /I <sub>set</sub> ratio 0.95)	±1.0 % or ±30 ms
Instant operation time	
Start time and instant operation time (trip): (I <sub>m</sub> /I <sub>set</sub> ratio 1.05)	<50 ms
Reset	
Reset ratio	97 % of pick-up current setting
Reset time setting Inaccuracy: Reset time	0.010 to 150.000 s, step 0.005 s ±1.0 % or ±35 ms
Instant reset time and start-up reset	<50 ms

**NOTE** Mechanical jam protection requires motor running condition before possible tripping.

## 2.7.3 Start/locked rotor (48,14) IST>

<b>Input signals</b>	
Input magnitudes	Phase current fundamental frequency RMS
<b>Pick-up</b>	
Pick-up current setting	0.10 to 40.00 x I <sub>n</sub> , setting step 0.10 x I <sub>n</sub>
Inaccuracy - Current	±0.5 % I <sub>SET</sub> or ±15 mA (0.10 to 4.0 x I <sub>SET</sub> )
<b>Operation time</b>	
Definite time function operating time setting	0.00 to 1800.00 s, setting step 0.005 s
Cumulative I <sup>2</sup> t sum inverse operation time	0.00 to 1800.00 s, setting step 0.005 s
Inaccuracy - Definite Time (I <sub>m</sub> /I <sub>set</sub> ratio 0.95)	±1.0 % or ±40 ms
<b>Instant operation time</b>	
Start time and instant operation time (trip): (I <sub>m</sub> /I <sub>set</sub> ratio 1.05)	<55 ms
<b>Reset</b>	
Reset ratio	97 % of pick-up current setting
Reset time setting Inaccuracy: Reset time	0.010 to 150.000 s, step 0.005 s ±1.0 % or ±35 ms
Instant reset time and start-up reset	<55 ms
<b>Time settings</b>	
Starting time setting	0.00 to 1800.00 s, setting step 0.005 s
Operating mode	Definite time or cumulative I <sup>2</sup> t sum inverse operating time either with or without speed switch input. Only starts or starts and stall monitoring
Start time	Max. 5 ms from detected start-up or locked rotor situation
Inaccuracy • Starting • Definite Time operating time	±3 % of set pick-up value > 0.5 x I <sub>n</sub> setting. 5 mA < 0.5 x I <sub>n</sub> setting ±0.5 % or ±10 ms

## 2.7.4 Frequent start protection (66/86) N>

<b>Inputs</b>	
Input magnitudes	Motor start monitor set start signals
Dependent of motor thermal status	Yes
<b>Settings</b>	
Starts when cold	1 to 100 starts by step of 1 start
Starts when hot	1 to 100 starts by step of 1 start
<b>Output data</b>	
Monitor data	Used starts Available starts Alarms, Inhibits, Blocks Inhibit, Alarm time on Time since last start
<b>Operation</b>	
Start time	Max. 5 ms from detected start-up
<b>Inaccuracy</b>	

Starting	$\pm 3\%$ of set pick-up value $> 0.5 \times I_n$ setting. $5 \text{ mA} < 0.5 \times I_n$ setting (from MST function)
Definite Time operating time	$\pm 0.5\%$ or $\pm 10 \text{ ms}$ of the counter deduct

## 2.8 Generator protections

### 2.8.1 Under-impedance (21) Z<

<b>Input signals</b>	
Input magnitudes	P-P impedances P-P and P-E impedances
<b>Pick-up</b>	
Pick-up setting	0.1 to 150.0 Ohm, setting step 0.1 Ohm
Inaccuracy - Impedance calculation	Typically $< 1.0\%$ $Z_{SET}$
<b>Operation time</b>	
Definite time function operating time setting	0.00 to 1800.00 s, setting step 0.005 s
Inaccuracy - Definite Time ( $Z_m/Z_{set}$ ratio $< 0.95$ )	$\pm 1.0\%$ or $\pm 25 \text{ ms}$
<b>Instant operation time</b>	
Start time and instant operation time (trip): ( $Z_m/Z_{set}$ ratio $< 0.95$ )	$< 45 \text{ ms}$
<b>Reset</b>	
Reset ratio	$0.97 \times Z_{set}$
Reset time setting Inaccuracy: Reset time	0.010 to 150.000 s, step 0.005 s $\pm 1.0\%$ or $\pm 25 \text{ ms}$
Instant reset time and start-up reset	$< 45 \text{ ms}$

- NOTE**
- **Impedance calculation:** Voltage measurement starts from 0.5 V and current measurement from 50 mA. In case either or both is missing the impedance measurement is forced to infinite.
  - **Angle memory:** During three phase short circuits the angle memory is active for 0.5 seconds in case the voltage drops below squelch limit (0.5 V). During this 0.5 seconds the impedance is calculated based to 1.0 V secondary voltage value and voltage angles before the fault.

### 2.8.2 Over-excitation (24) V/HZ>

<b>Input signals</b>	
Input magnitudes	P-P voltage fundamental frequency RMS P-E voltage fundamental frequency RMS
Frequency reference1 Frequency reference2 Frequency reference3	CT1IL1, CT2IL1, VT1U1, VT2U1 CT1IL2, CT2IL2, VT1U2, VT2U2 CT1IL3, CT2IL3, VT1U3, VT2U3
<b>Pick-up</b>	
Pick-up V/Hz setting	1.00 to 30.00 %, setting step 0.01 %
Inaccuracy - V/Hz	$\pm 1.0\%$
<b>Operation time</b>	
Definite time function operating time setting	0.00 to 1800.00 s, setting step 0.005 s
Inaccuracy - Definite Time (m/set ratio 1.05)	$\pm 1.0\%$ or $\pm 25 \text{ ms}$
<b>Instant operation time</b>	

Start time and instant operation time (trip): (m/set ratio 1.05)	<40 ms
<b>Reset</b>	
Reset ratio	99 % of pick-up setting
Reset time setting Inaccuracy: Reset time	0.010 to 150.000 s, step 0.005 s ±1.0 % or ±25 ms
Instant reset time and start-up reset	<40 ms

**NOTE Measurement:** Volt per hertz protection is checking the highest line to line voltage. Used sampling mode for frequency has to be "Tracking".

### 2.8.3 Under-excitation (40) Q<

<b>Input signals</b>	
Input magnitudes	Phase current and voltage fundamental frequency RMS
<b>Pick-up</b>	
Pick-up setting	0.10 to 100000.00 kvar, setting step 0.01 kvar
Inaccuracy - Reactive power	Typically < 1.0 % QSET
<b>Operation time</b>	
Definite time function operating time setting	0.00 to 1800.00 s, setting step 0.005 s
Inaccuracy - Definite Time (Qm/Qset ratio 1.05→)	±1.0 % or ±35 ms
<b>Instant operation time</b>	
Start time and instant operation time (trip): (Qm/Qset ratio 0.95)	<50 ms
<b>Reset</b>	
Reset ratio	0.97 x Qset
Reset time setting Inaccuracy: Reset time	0.010 to 150.000 s, step 0.005 s ±1.0 % or ±35 ms
Instant reset time and start-up reset	<50 ms

**NOTE** Voltage measurement starts from 0.5 V and current measurement from 50 mA. In case either or both is missing the reactive power measurement is 0 kvar.

### 2.8.4 Voltage-restrained over-current (51V) IV>

<b>Input signals</b>	
Input voltage magnitudes	P-P voltage fundamental frequency RMS P-E voltage fundamental frequency RMS
Input current magnitudes	Phase current fundamental frequency RMS
<b>Pick-up</b>	
Pick-up current setting (point 1 &2)	0.10 to 40.00 x I <sub>n</sub> , setting step 0.01 x I <sub>n</sub>
Pick-up voltage setting (point 1 &2)	0.05 to 150.00 % U <sub>n</sub> , setting step 0.01 % U <sub>n</sub>
Inaccuracy • Current • Voltage	±0.5 % I <sub>SET</sub> or ±15 mA (0.10 to 4.0 x I <sub>SET</sub> ) ±1.5 % U <sub>SET</sub> or ±30 mV
<b>Operation time</b>	
Definite time function operating time setting	0.00 to 1800.00 s, setting step 0.005 s

Inaccuracy - Definite Time ( $I_m/I_{set}$ ratio 1.05→)	±1.0 % or ±25 ms
IDMT operating time setting (ANSI/IEC)	0.02 to 1800.00 s, setting step 0.001 x parameter
<b>IDMT setting parameters</b>	
k Time dial setting for IDMT	0.01 to 25.00 step 0.01
A IDMT Constant	0 to 250.0000 step 0.0001
B IDMT Constant	0 to 5.0000 step 0.0001
C IDMT Constant	0 to 250.0000 step 0.0001
<b>Inaccuracy</b>	
• IDMT operating time	±1.5 % or ±20 ms
• IDMT minimum operating time; 20 ms	±20 ms
<b>Instant operation time</b>	
Start time and instant operation time (trip): ( $I_m/I_{set}$ ratio 1.05→)	<40 ms
<b>Reset</b>	
Reset ratio - Current	97 % of pick-up current setting
Reset time setting	0.000 to 150.000 s, step 0.005 s
Inaccuracy: Reset time	±1.0 % or ±25 ms
Instant reset time and start-up reset	<45 ms

## 2.8.5 100 % stator earth fault protection (64S) U03RD<

<b>Input signals</b>	
Input voltage magnitudes	Zero sequence voltage fundamental frequency RMS
<b>Pick-up</b>	
Pick-up voltage setting	1.00 to 95.00 % $U_{0n}$ , setting step 0.01 % $U_{0n}$
Inaccuracy - U03rd	±1.0 % $U_{0SET}$ or ±50 mV
<b>Low current blocking</b>	
No load –current setting	0.00 to 1.00 x $I_n$ , setting step 0.01 x $I_n$
Inaccuracy - Starting I1	±1.0 % $I_{1SET}$ or ±100 mA (0.10 to 4.0 x $I_N$ )
<b>Operation time</b>	
Definite time function operating time setting	0.00 to 1800.00 s, setting step 0.005 s
Inaccuracy - Definite Time ( $I_m/I_{set}$ ratio 0.95)	±1.0 % or ±30 ms
<b>Instant operation time</b>	
Start time and instant operation time (trip): ( $U_m/U_{set}$ ratio 0.95)	<60 ms
<b>Reset</b>	
Reset ratio	103 % of pick-up voltage setting
Reset time setting	0.010 to 150.000 s, step 0.005 s
Inaccuracy: Reset time	±1.0 % or ±30 ms
Instant reset time and start-up reset	<45 ms

**NOTE No load-current setting:** The no load-current setting of 0.00 x  $I_n$  is only for commissioning. When using the relay under normal conditions always use 0.01 x  $I_n$  or greater.

## 2.8.6 Pole slip (78G) PS

Input signals	
Input magnitudes	Phase current fundamental frequency RMS P-E voltage fundamental frequency RMS P-P + U0 voltage fundamental frequency RMS (calc. P-E)
Suitable voltage measurement modes	
Voltage measurement mode	3LN+U4 3LL+U4 (when U4 is used as U0) 2LL+U3+U4 (when either U3 or U4 is used as U0) 3LN (LEA req. HW)
Pick-up	
Characteristic (Lens) settings	
• Forward reactive reach Xfwd	-0.20 to -25.00 $\Omega$ , setting step 0.01 $\Omega$
• Reverse reactive reach Xrev	0.20 to 25.00 $\Omega$ , setting step 0.01 $\Omega$
• Resistive reach Rfwd	0.20 to 25.00 $\Omega$ , setting step 0.01 $\Omega$
• Lens inclination $\alpha$	90.00 to 45.00°, setting step 0.01°
Zone1/Zone2 (slip center detection) - System side swing reach Sfwd	20.00 to 100.00 % of Xfwd, setting step 0.01 %
Inaccuracy	
• Impedance	$\pm 5.0$ % $Z_{SET}$ (typically)
• Angle	$\pm 0.15^\circ$
• Angle (U = 1 to 15 V)	$\pm 1.5^\circ$
• dZ/dt	$\pm$
Timers	
Slip timers	
• State transition time (dZ/dt)	0.020 to 0.200 s, setting step 0.005 s
• Max. slip time	0.10 to 60.00 s, setting step 0.01 s
Inaccuracy - Definite Time	$\pm 1.0$ % or $\pm 20$ ms
Number of slips	
Number of slips to trip	1 to 10, setting step 1
Reset	
Reset ratio - Impedance	103 % of pick-up impedance setting
Instant reset time and start-up reset	<50 ms

**NOTE** Minimum voltage for direction solving is 1.0 V secondary.

## 2.9 Transformer protections

### 2.9.1 Transformer thermal overload (49T) T>

Input signals	
Input current magnitude	Phase current TRMS max. (up to 31st harmonic)
Setting specifications	
Time constants $\tau$	1 heating, 1 cooling
Time constant value	0.0 to 500.00 min by step of 0.1 min
Service factor (max. overloading)	0.01 to 5.00 by step of 0.01 x In
Thermal model biasing	<ul style="list-style-type: none"> <li>Ambient temperature (Set -60.0 to 500.0 ° by step of 0.1 °)</li> <li>Negative sequence current</li> </ul>



Thermal replica temperature estimates	Selectable °C or °F
Outputs	Alarm 1 (0 to 150 % by step of 1 %) Alarm 2 (0 to 150 % by step of 1 %) Thermal Trip (0 to 150 % by step of 1 %) Trip delay (0.000 to 3600.000 s by step of 0.005 s) Restart Inhibit (0 to 150 % by step of 1 %)
<b>Inaccuracy</b>	
Starting	±0.5 % of set pick-up value
Operating time	±5 % or ± 500 ms

## 2.9.2 Transformer differential (87T,87R) IDB>, IDI>, HV I0D>, LV I0D>

<b>Input signals</b>	
Input magnitudes	Phase currents of HV/LV side. Fundamental residual current measurement for HV/LV REF protection. 2nd and 5th harmonic measurement.
<b>Characteristic (Differential and REF)</b>	
Differential calculation mode	Add or Subtract (CT direction)
Bias calculation mode	Average or maximum (Sensitivity)
I <sub>db</sub> > Pick-up	0.01 to 100.00 % by step of 0.01 %, default 10.00 %
Turnpoint 1	0.01 to 50.00 x I <sub>n</sub> by step of 0.01 x I <sub>n</sub> , default 1.00 x I <sub>n</sub>
Slope 1	0.01 to 250.00 % by step of 0.01 %, default 10.00 %
Turnpoint 2	0.01 to 50.00 x I <sub>n</sub> by step of 0.01 x I <sub>n</sub> , default 3.00 x I <sub>n</sub>
Slope 2	0.01 to 250.00 % by step of 0.01 %, default 200.00 %
I <sub>di</sub> > Pick-up	200.00 to 1500.00 % by step of 0.01 %, default 600.00 %
Internal harmonic blocking selection	None, 2nd harmonic, 5th harmonic, both.
2nd harmonic blocking Pick-up	0.01 to 50.00 % by step of 0.01 %, default 15.00 %
5th harmonic blocking Pick-up	0.01 to 50.00 % by step of 0.01 %, default 35.00 %
Inaccuracy	
Differential current	±3.0 % I <sub>SET</sub> or ±75 mA (0.10 to 4.0 x I <sub>SET</sub> )
2nd harmonic	±1.5 % I <sub>SIDE1</sub>
<b>Instant operation time</b>	
Instant operation time >1.05 x I <sub>SET</sub>	<40 ms (Harmonic blocking active)
Instant operation time >3.00 x I <sub>SET</sub>	<30 ms (Harmonic blocking active)
Instant operation time >3.00 x I <sub>SET</sub>	~15 ms (No harmonic blocking)
<b>Reset</b>	
Reset ratio: Differential current	97 % typically of differential current setting
Reset time	<50 ms

**NOTE** Harmonic current is set and calculated according to the highest amplitude of side 1, 2 or 3 currents (I<sub>h</sub>%/I<sub>SIDE1/2/3</sub>).  
Harmonic current is calculated individually for each phase.

## 2.9.3 Transformer differential (87G,87R) IDB>, IDI>, HV I0D>, LV I0D>

<b>Input signals</b>	
Input magnitudes	Phase currents of HV/LV side. Fundamental residual current measurement for HV/LV REF protection. 2nd and 5th harmonic measurement.
<b>Characteristic (Differential and REF)</b>	

Differential calculation mode	Add or Subtract (CT direction)
Bias calculation mode	Average or maximum (Sensitivity)
I <sub>db</sub> > Pick-up	0.01 to 100.00 % by step of 0.01 %, default 10.00 %
Turnpoint 1	0.01 to 50.00 x I <sub>n</sub> by step of 0.01 x I <sub>n</sub> , default 1.00 x I <sub>n</sub>
Slope 1	0.01 to 250.00 % by step of 0.01 %, default 10.00 %
Turnpoint 2	0.01 to 50.00 x I <sub>n</sub> by step of 0.01 x I <sub>n</sub> , default 3.00 x I <sub>n</sub>
Slope 2	0.01 to 250.00 % by step of 0.01 %, default 200.00 %
I <sub>di</sub> > Pick-up	200.00 to 1500.00 % by step of 0.01 %, default 600.00 %
Internal harmonic blocking selection	None, 2nd harmonic, 5th harmonic, both.
2nd harmonic blocking Pick-up	0.01 to 50.00 % by step of 0.01 %, default 15.00 %
5th harmonic blocking Pick-up	0.01 to 50.00 % by step of 0.01 %, default 35.00 %
Inaccuracy - Differential current	±3.0 % I <sub>SET</sub> or ±75 mA (0.10 to 4.0 x ISET)
<b>Instant operation time</b>	
Instant operation time >1.05 x I <sub>SET</sub>	<40 ms (Harmonic blocking active)
Instant operation time >3.00 x I <sub>SET</sub>	<30 ms (Harmonic blocking active)
<b>Reset</b>	
Reset ratio: Differential current	97 % typically of differential current setting
Reset time	<50 ms

## 2.9.4 Transformer monitoring function (TRF)

<b>Features</b>	
Control scale	Common transformer data settings for all functions in transformer module, protection logic, HMI and IO.
Settings	Transformer application nominal data
Other features	Status hours counters (normal load, overload, high overload) Transformer status signals Transformer data for functions
<b>Outputs</b>	
Light/no load	I <sub>m</sub> < 0.2 x I <sub>n</sub>
Inrush HV side detected	I <sub>m</sub> < 0.2 x I <sub>n</sub> → I <sub>m</sub> >1.3 x I <sub>n</sub>
Inrush LV side detected	I <sub>m</sub> < 0.2 x I <sub>n</sub> → I <sub>m</sub> >1.3 x I <sub>n</sub>
Load normal	I <sub>m</sub> > 0.2 x I <sub>n</sub> to I <sub>m</sub> <1.0 x I <sub>n</sub>
Overloading	I <sub>m</sub> > 1.0 x I <sub>n</sub> to I <sub>m</sub> <1.3 x I <sub>n</sub>
High overload	I <sub>m</sub> > 1.3 x I <sub>n</sub>
<b>Inaccuracy</b>	
Current detection	±3 % of set pick-up value > 0.5 x I <sub>n</sub> setting. 5 mA < 0.5 x I <sub>n</sub> setting
Detection time	±0.5 % or ±10 ms

## 2.9.5 Under-impedance (21) Z<

<b>Input signals</b>	
Input magnitudes	P-P impedances P-P and P-E impedances
<b>Pick-up</b>	

Pick-up setting	0.1 to 150.0 Ohm, setting step 0.1 Ohm
Inaccuracy - Impedance calculation	Typically <1.0 % Z <sub>SET</sub>
<b>Operation time</b>	
Definite time function operating time setting	0.00 to 1800.00 s, setting step 0.005 s
Inaccuracy - Definite Time (Z <sub>m</sub> /Z <sub>set</sub> ratio <0.95)	±1.0 % or ±25 ms
<b>Instant operation time</b>	
Start time and instant operation time (trip): (Z <sub>m</sub> /Z <sub>set</sub> ratio <0.95)	<45 ms
<b>Reset</b>	
Reset ratio	0.97 x Z <sub>set</sub>
Reset time setting	0.010 to 150.000 s, step 0.005 s
Inaccuracy: Reset time	±1.0 % or ±25 ms
Instant reset time and start-up reset	<45 ms

- NOTE**
- **Impedance calculation:** Voltage measurement starts from 0.5 V and current measurement from 50 mA. In case either or both is missing the impedance measurement is forced to infinite.
  - **Angle memory:** During three phase short circuits the angle memory is active for 0.5 seconds in case the voltage drops below squelch limit (0.5 V). During this 0.5 seconds the impedance is calculated based to 1.0 V secondary voltage value and voltage angles before the fault.

## 2.9.6 Over-excitation (24) V/Hz>

<b>Input signals</b>	
Input magnitudes	P-P voltage fundamental frequency RMS P-E voltage fundamental frequency RMS
Frequency reference1	CT1IL1, CT2IL1, VT1U1, VT2U1
Frequency reference2	CT1IL2, CT2IL2, VT1U2, VT2U2
Frequency reference3	CT1IL3, CT2IL3, VT1U3, VT2U3
<b>Pick-up</b>	
Pick-up V/Hz setting	1.00 to 30.00 %, setting step 0.01 %
Inaccuracy - V/Hz	±1.0 %
<b>Operation time</b>	
Definite time function operating time setting	0.00 to 1800.00 s, setting step 0.005 s
Inaccuracy - Definite Time (m/set ratio 1.05)	±1.0 % or ±25 ms
<b>Instant operation time</b>	
Start time and instant operation time (trip): (m/set ratio 1.05)	<40 ms
<b>Reset</b>	
Reset ratio	99 % of pick-up setting
Reset time setting	0.010 to 150.000 s, step 0.005 s
Inaccuracy: Reset time	±1.0 % or ±25 ms
Instant reset time and start-up reset	<40 ms

- NOTE** **Measurement:** Volt per hertz protection is checking the highest line to line voltage. Used sampling mode for frequency has to be "Tracking".

## 2.9.7 Automatic voltage regulator (90) AVR (Transformer)

Input signals	
Input magnitudes	U12, U23, U31 or U4 channel IL1, IL2, IL3 (I> blocking)
Pick-up	
Pick-up area (U>/<, U>>/<<, U>>>/<<<) Tap step effect (1 to 70 steps) I> blocking	0.10 to 30.00 % Un, setting step 0.01 % Un 0.01 to 10.00 % Un, setting step 0.01 % Un 0.00 to 40.00 x In, setting step 0.01 x In
Inaccuracy Voltage Current	±1.5 % U <sub>SET</sub> ±0.5 % I <sub>SET</sub> or ±15 mA (0.10 to 4.0 x I <sub>SET</sub> )
Operating time	
Control pulse min./max. and time between Definite time function operating time setting	0.00 to 1800.00 s, setting step 0.005 s 0.00 to 1800.00 s, setting step 0.005 s
Inaccuracy - Definite Time (Um/Uset ratio 1.05)	±1.5 % or ±50 ms
Integrated operating time setting - Multiplier (k)	0.000 to 1800.00, setting step 0.005
Inaccuracy IDMT operating time IDMT minimum operating time; 20 ms	±1.5 % or ±35 ms ±20 ms
Instant operation time	
Start time and instant operation time (trip): Um/Uset ratio 1.05→	<50 ms
Reset	
Reset ratio Voltage Current	95/105 % of pick-up voltage setting 97 % of pick-up current setting
Reset time setting Inaccuracy: Reset time	0.010 to 10.000 s, step 0.005 s ±1.0 % or ±35 ms
Instant reset time and start-up reset	<50 ms

## 2.10 Control functions

### 2.10.1 Synchrocheck (25) SYN1, SYN2, SYN3

Input signals	
Input magnitudes	P-P voltage fundamental frequency RMS P-E voltage fundamental frequency RMS
Pick-up	
U diff < setting	2.00 to 50.00 % Un, setting step 0.01 %Un
Angle diff < setting	3.0 to 90.0°, setting step 0.10°
Freq diff < setting	0.05 to 0.50 Hz, setting step 0.01 Hz
Inaccuracy • Voltage • Frequency • Angle	±3.0 % U <sub>SET</sub> or ±0.3 % U <sub>N</sub> ±25 mHz (U > 30 V secondary) ±1.5°(U > 30 V secondary)
Reset	
Reset ratio	99 % of pick-up voltage setting

• Voltage	
• Frequency	20 mHz
• Angle	$\pm 2.0^\circ$
<b>Activation time</b>	
Activation (to LD/DL/DD)	<35 ms
Activation (to Live Live)	<60 ms
Reset	<40 ms
<b>Bypass modes</b>	
Voltage check mode (excluding LL)	LL+LD, LL+DL, LL+DD, LL+LD+DL, LL+LD+DD, LL+DL+DD, bypass
U live > limit	0.10 to 100.00 % Un, setting step 0.01 % Un
U dead < limit	0.00 to 100.00 % Un, setting step 0.01 % Un

- NOTE**
- Voltage is scaled to primary amplitude. Therefore different sized PT secondary are possible.
  - Minimum voltage for direction and frequency solving is 20.0 % Un.
  - U dead limit is not in use when set to 0 % Un.
  - When SYN3 is used, SYN1 and SYN2 must have same reference voltage.
  - In 3LN mode synchronization to L-N and L-L voltage both is possible. In 3LL/2LL modes synchronization only to L-L voltage is supported solution.

## 2.10.2 Cold load pick-up (68) CLP

<b>Input signals</b>	
Input magnitudes	Phase current fundamental frequency RMS
<b>Pick-up</b>	
Pick-up current setting - I Low/I High/I Over	0.01 to 40.00 x In, setting step 0.01 x In
Reset ratio	97/103 % of pick-up current setting
Inaccuracy - Current	$\pm 0.5\%$ I <sub>SET</sub> or $\pm 15$ mA (0.10 to 4.0 x I <sub>SET</sub> )
<b>Operation time</b>	
Definite time function operating time setting CLPU tset/CLPU tmax CLPU tmin	0.000 to 1800.000 s, setting step 0.005 s 0.020 to 1800.000 s, setting step 0.005 s
Inaccuracy - Definite Time (Im/Iset ratio = 1.05/0.95)	$\pm 1.0\%$ or $\pm 45$ ms
<b>Instant operation time</b>	
CLPU activation and release	<45 ms (measured from trip contact)

- NOTE** One phase current (IL1, IL2 or IL3) is enough to prolong blocking or to release blocking during an over-current condition.

## 2.10.3 Switch on to fault (SOTF)

<b>Initialization signals</b>	
SOTF activate input	Any IED block input signal (Object closed signal etc.)
<b>Pick-up</b>	
SOTF function input	Any IED block input signal (> or similar)
<b>SOTF activation time</b>	
Activation time	<40 ms (measured from trip contact)
<b>SOTF release time</b>	

Release time setting	0.000 to 1800.000 s, setting step 0.005 s
Inaccuracy - Definite Time	±1.0 % or ±30 ms
SOTF instant release time	<40 ms (measured from trip contact)

## 2.10.4 Object control

<b>Signals</b>	
Input signals	Binary inputs Software signals
Output signals	Close command output Open command output
<b>Operation time</b>	
Breaker traverse time setting	0.02 to 500.00 s, setting step 0.02 s
Max. close/open command pulse length	0.02 to 500.00 s, setting step 0.02 s
Control termination time out setting	0.02 to 500.00 s, setting step 0.02 s
Inaccuracy - Definite Time operating time	±0.5 % or ±10 ms
<b>Breaker control operation time</b>	
External object control time	<75 ms
Object control during Auto-reclosing	See Auto-reclosing technical sheet

## 2.10.5 Setting group selection

<b>Settings and control modes</b>	
Setting groups	8 independent control prioritized setting groups
Control scale	Common for all installed functions which support setting groups
<b>Control mode</b>	
Local	Any digital signal available in the device
Remote	Force change overrule of local controls either from setting tool, HMI or SCADA
<b>Operation time</b>	
Reaction time	<5 ms from receiving the control signal

## 2.11 Monitoring functions

### 2.11.1 Fuse failure (60) VTS

<b>Input signals</b>	
Measured magnitudes	P-P voltage fundamental frequency RMS P-E voltage fundamental frequency RMS
<b>Pickup</b>	
Pickup setting • Voltage low pickup • Voltage high pickup • Angle shift limit	0.05 to 0.50 x Un, setting step 0.01 x Un 0.50 to 1.10 x Un, setting step 0.01 x Un 2.00 to 90.00°, setting step 0.10°
Inaccuracy • Voltage	±1.5 % U <sub>SET</sub> ±1.5°

• U angle(U > 1 V)	
External line/bus side pickup (optional)	0 → 1
<b>Time delay for alarm</b>	
Definite time function operating time setting	0.00 to 1800.00 s, setting step 0.005 s
Inaccuracy - Definite Time (Um/Uset ratio > 1.05/0.95)	±1.0 % or ±35 ms
Instant operation time (alarm): (Um/Uset ratio > 1.05/0.95)	<80 ms
VTS MCB trip bus/line (external input)	<50 ms
<b>Reset</b>	
Reset ratio	97/103 % of pickup voltage setting
Reset time setting	0.010 to 10.000 s, step 0.005 s
Inaccuracy: Reset time	±2.0 % or ±80 ms
Instant reset time and start-up reset	<50 ms
VTS MCB trip bus/line (external input)	<50 ms

**NOTE** When turning on auxiliary power of IED the normal condition of stage has to be fulfilled before tripping.

### 2.11.2 Circuit breaker wear monitor (CBW)

<b>Pick-up</b>	
Breaker characteristics settings:	
• Nominal breaking current	0.00 to 100.00 kA by step of 0.001 kA
• Maximum breaking current	0.00 to 100.00 kA by step of 0.001 kA
• Operations with nominal current	0 to 200000 operations by step of 1 operation
• Operations with maximum breaking current	0 to 200000 operations by step of 1 operation
Pick-up setting for Alarm 1 and Alarm 2	0 to 200000 operations, setting step 1 operation
<b>Inaccuracy</b>	
Inaccuracy for current/operations counter	
• Current measurement element	.1 x In > I < 2 x In ±0.2 % of measured current, rest 0.5 %
• Operation counter	±0.5 % of operations deducted

### 2.11.3 Disturbance recorder (DR)

<b>Recorded values</b>	
Recorder analogue channels	0 to 9 channels Freely selectable
Recorder digital channels	0 to 32 channels Freely selectable analogue and binary signals 5 ms sample rate (FFT)
<b>Performance</b>	
Sample rate	8, 16, 32 or 64 sample/cycle
Recording length	0.1 to 1800, setting step 0.001 Maximum length according to chosen signals
Number of recordings	0 to 100, 60 MB shared flash memory reserved Maximum number of recordings according to chosen signals and operation time setting combined

## 2.11.4 Current transformer supervision (CTS)

Input signals	
Input magnitudes	Phase current fundamental frequency RMS Residual current fundamental frequency RMS (optional)
Pick-up	
Pick-up current setting • Iset high limit, Iset low limit, Isum difference • Iset ratio, I2/I1 ratio	0.10 to 40.00 x I <sub>N</sub> , setting step 0.01 x I <sub>N</sub> 0.01 to 100.00 %, setting step 0.01 %
Inaccuracy • Starting IL1, IL2, IL3 • Starting I2/I1 • Starting I01 (1 A) • Starting I02 (0.2 A)	±0.5 % I <sub>SET</sub> or ±15 mA (0.10 to 4.0 x I <sub>SET</sub> ) ±1.0 % I <sub>2SET</sub> /I <sub>1SET</sub> or ±100 mA (0.10 to 4.0 x I <sub>N</sub> ) ±0.5 % I <sub>0SET</sub> or ±3 mA (0.005 to 10.0 x I <sub>SET</sub> ) ±1.5 % I <sub>0SET</sub> or ±1.0 mA (0.005 to 25.0 x I <sub>SET</sub> )
Time delay for alarm	
Definite time function operating time setting	0.00 to 1800.00 s, setting step 0.005 s
Inaccuracy - Definite Time (I <sub>m</sub> /I <sub>set</sub> ratio > 1.05)	±2.0 % or ±80 ms
Instant operation time (alarm): (I <sub>m</sub> /I <sub>set</sub> ratio > 1.05)	<80 ms (<50 ms in differential protection relays)
Reset	
Reset ratio	97/103 % of pick-up current setting
Reset time setting	0.010 to 10.000 s, step 0.005 s,
Inaccuracy - Reset time	±1.0 % or ±35 ms
Instant reset time and start-up reset	<80 ms (<50 ms in differential protection relays)

## 2.11.5 Total harmonic distortion (THD)

Input signals	
Input magnitudes	Current measurement channels FFT result up to 31st harmonic component
Pick-up	
Operating modes	Power THD Amplitude THD
Pick-up setting for all comparators	0.10 to 200.00 % , setting step 0.01 %
Inaccuracy	±3 % of set pick-up value > 0.5 x I <sub>N</sub> setting. 5 mA < 0.5 x I <sub>N</sub> setting
Time delay	
Definite time function operating time setting for all timers	0.00 to 1800.00 s, setting step 0.005 s
Inaccuracy Definite time operating time Instant operating time, when I <sub>m</sub> /I <sub>set</sub> ratio > 3 Instant operating time, when I <sub>m</sub> /I <sub>set</sub> ratio 1.05 < I <sub>m</sub> /I <sub>set</sub> < 3	±0.5 % or ±10 ms Typically <20 ms Typically <25 ms
Reset	
Reset time	Typically <10 ms
Reset ratio	97 %



## 2.11.6 Voltage memory (integrated in 67,21G)

<b>Input signals</b>	
Input magnitudes	P-P voltage fundamental frequency RMS P-E voltage fundamental frequency RMS Phase current fundamental freq RMS/(back-up frequency)
<b>Pick-up</b>	
Pick-up voltage setting Pick-up current setting (optional)	2.00 to 50.00 % Un, setting step 0.01 x % Un 0.01 to 50.00 x In, setting step 0.01 x In
Inaccuracy Voltage Current	$\pm 1.5\% U_{SET}$ or $\pm 30$ mV $\pm 0.5\% I_{SET}$ or $\pm 15$ mA (0.10 to 4.0 x $I_{SET}$ )
<b>Operation time</b>	
Angle memory activation delay	<20 ms (typically 5ms)
Maximum active time	0.020 to 50.000 s, setting step 0.005 s
Inaccuracy - Definite Time ( $U_m/U_{set}$ ratio >1.05)	$\pm 1.0\%$ or $\pm 35$ ms
<b>Angle memory</b>	
Angle drift while voltage is absent	$\pm 1.0^\circ$ per 1 second
<b>Reset</b>	
Reset ratio Voltage memory (voltage) Voltage memory (current)	103 % of pick-up voltage setting 97 % of pick-up current setting
Reset time	<50 ms

## 3. Technical specifications

### 3.1 Electromagnetic compatibility

Emission	Standard	Class	Value
Conducted Disturbance Emission	IEC 60255-26	A	0.15 to 30 MHz IACS E10 Setup according to CISPR 16. Conducted emission measured from 10kHz
	IEC 61000-6-4	A	
Radiated emission (below 1 GHz)	IEC 60255-26		30 to 1000 MHz
	IEC 61000-6-4	A	IACS E10 Setup according to CISPR 16. Radiated emission measured from 150 kHz to 2000 MHz
Radiated emission (above 1 GHz)	IEC 60255-26		1 to 6 GHz
	IEC 61000-6-4	A	

Immunity	Standard	Level	Value
Electrostatic Discharge	IEC 60255-26		8 kV air discharge
	IEC 61000-4-2 IACS E10	3	6 kV direct discharge
Radiated immunity	IEC 60255-26		10 V/m; 80 MHz to 1 GHz; 1.4 GHz to 2.7 GHz IACS E10 80 MHz to 2 GHz 10 V/m 3 s dwell time
	ENV 50204 (GSM)	3	10 V/m; 2 W at 0.6 m
Fast transient/burst immunity	IEC 60225-26		2 kV
	IEC 61000-4-4 IACS E10	3	2 kV 2 kV
Surge immunity	IEC 60255-26		1 kV symmetrical (line to line)
	IEC 61000-4-5 IACS E10	3	2 kV unsymmetrical (line to earth) 0.5 kV symmetrical (line to line) (only for IACS E10) 1 kV unsymmetrical (line to earth) (only for IACS E10)
Conducted immunity	IEC 60255-26		0.15 to 80 MHz; 10 V
	IEC 61000-4-6	3	IACS E10 3 s dwell time.
Power frequency magnetic field immunity	IEC 60255-26		30 A/m continuous
	IEC 61000-4-8	4	300 A/m; 1 s to 3 s
Pulse magnetic field immunity	IEC 61000-4-9	5	1000 A/m
Damped oscillatory magnetic field immunity	IEC 61000-4-10	4	30 A/m
Oscillatory transient immunity – Ring wave	IEC 61000-4-12	4	100 kHz 4 kV common mode
			2 kV differential mode
Oscillatory transient immunity – Slow damped oscillatory wave	IEC 61000-4-18 ANSI/IEEE Std C37.90.1	3	100 kHz 1 kV differential mode 2.5 kV common mode
Oscillatory transient immunity – Slow damped oscillatory wave	IEC 60255-26 IEC 61000-4-18	3	1.0 MHz 2.5 kV common mode
	ANSI/IEEE Std C37.90.1		2.5 kV differential mode

Immunity	Standard	Level	Value
Voltage dips	IEC 60255-26		0 %
	IEC 61000-4-11		DC 10 ms
	IEC 61000-4-29		AC 0.5 cycle (10 ms)
Voltage dips	IEC 60255-26		40 %
	IEC 61000-4-11		DC 200 ms
	IEC 61000-4-29		AC 10/12 cycles (10 ms) Tested both 50/60 Hz
Voltage dips	IEC 60255-26		70 %
	IEC 61000-4-11		DC 500 ms
	IEC 61000-4-29		AC 25/30 cycles (10 ms)
Voltage interruptions	IEC 60255-26		0 %
	IEC 61000-4-11 IACS E10		DC 5 s (3 interruptions w. 10 s interval) DC 30 s/60 s (3 interruptions w. 60 s interval)
	IEC 61000-4-29 IACS E10		AC 250 cycles (5 s) (3 interruptions w. 10 s interval) AC 30 s (3 interruptions w. 90 s interval) 1 additional interruption during booting
Voltage variations permanent	IACS E10		DC +30 % 24H DC -15 % 15 min AC +6 % V AC/+5 % Hz 15 min AC +6 % V AC/-5 % Hz 15 min AC -10 % V AC/-5 % Hz 15min AC -10 % V AC/+5 % Hz 15 min
Voltage variations transient	IACS E10		AC +20 % V AC 1.5 s/+10 % Hz 5 s AC -20 % V AC 1.5 s/-10 % Hz 5 s
Ripple	IEC 60255-26		15 % of DC; 100 Hz
	IEC 61000-4-17		
Power Frequency Immunity	IEC 60255-26		150 V, 50 Hz, common mode
	IEC 61000-4-16		300 V, 50 Hz, differential mode

### 3.2 Mechanical durability

Energised	Standard	Class	Value
Vibration response	IEC 60255-27 IEC 60255-21-1	2	10 to 58.1 Hz: 0.15 mmpg 58.1 to 150 Hz: 1 g 1 cycle in each axis
Vibration	IACS E10		3 to 13.2 Hz 2 mmpg 13.2 to 100 Hz 0.7 g
Shock response	IEC 60255-27 IEC 60255-21-2	2	10 g; 11 ms

De-energised	Standard	Class	Value
Vibration endurance	IEC 60255-27 IEC 60255-21-1	2	10 to 150 Hz; 2 g acceleration; 20 sweep cycles
Shock withstand	IEC 60255-27	2	30 g; 11 ms

De-energised	Standard	Class	Value
	IEC 60255-21-2		
Bump	IEC 60255-27 IEC 60255-21-2	2	20 g; 16 ms

### 3.3 Environment

General	Standard	Value
Cold non-operation	I IEC 60255-27 IEC 60255-1 IACS E10	-25 °C; 16 h
Dry heat operation	IEC 60255-27 IEC 60255-1 IACS E10	60 °C; 16 h
Damp heat (static)	IEC 60255-27 IEC 60255-1	55 °C; 93 % RH; 10 days
Cyclic temperature with humidity (damp heat cyclic)	IEC 60255-27 IEC 60255-1 IACS E10	55 °C @ 93 % RH; 25 °C @ 97 % RH, 12 h + 12 h; 6 cycles 55 °C @ 95 % RH; 12 h + 12 h; 2 cycles
Change of temperature	IEC 60255-1	5 cycles; -25 °C to 70 °C

Storage	Standard	Value
Low temperature storage	IEC 60255-27 IEC 60255-1	-40 °C; 16 h
High temperature storage	IEC 60255-27 IEC 60255-1	70 °C; 16 h

### 3.4 Safety

Electrical	Standard	Value
Insulation resistance	IEC 60255-27 IACS E10	Before environmental tests: >100 MΩ at DC 500 V >100 MΩ at DC 500 V (Uw >65 V) >10 MΩ at DC 50 V (Uw <65 V) After environmental tests: >10 MΩ at DC 500 V (Uw >65 V) >1 MΩ at DC 50 V (Uw <65 V)
Reverse polarity	IEC 60255-27	
Gradual shut down/start-up tests	IEC 60255-27	
Impulse voltage	IEC 60255-27	5 kV; 1.2/50 μs; 0.5 J
Power frequency dielectric withstand	IEC 60255-27	3.5 kV; 50 Hz; 1 min (PS, DI, DO, I, RS485 AO) 4.35 kV; 50 Hz; 1 min (U)
Protective bonding impedance	IEC 60255-27	<0.1 Ω at 20 A 60 s
Insulation class		Class I
Over-voltage CAT	IEC 60255-27	III

Enclosure	Standard	Value
Dust/water ingress	IEC 60255-27 IEC 60529	IP 54 (front), IP 20 (back)

## 4. Hardware

### 4.1 Auxiliary supply

Rated voltage	
Low DC	Un: 24/48 V, +30/-25 %
	<b>Caution:</b> If the auxiliary supply working voltage is 24/48 V DC, do not use relay output SF with >150 V AC/DC.
High DC	Un: 100 to 125 V DC, +20/-10 %
Other	
Power consumption typically	
210 series	20 W
250 series	30 W
Maximum permitted interrupt time	<150 ms with 110 V DC
DC ripple	<15 %
Terminal block	
Solid or stranded wire	Maximum wire diameter: 2.5 mm <sup>2</sup>
Phoenix Contact MSTB2,5-5,08	
Phoenix Contact MSTB2,20-5,08	

### 4.2 Current measurement module

Measurement channels/CT inputs	
Three phase currents, One coarse residual current, and One sensitive residual current. Total of five separate CT inputs.	
Phase current inputs (A,B,C)	
Rated current In	5 A (configurable 0.2 A to 10 A)
Thermal withstand	30 A continuous 100 A for 10 s 500 A for 1 s 1250 A for 0.01 s
Frequency measurement range	From 6 Hz to 75 Hz fundamental, up to 31st harmonic current
Current measurement range	25 mA to 250 A (RMS)
Current measurement inaccuracy	0.005 x In to 20 x In <±0.5 % or <±15 mA 20 x In to 50 x In <±1.0 %
Angle measurement inaccuracy	<±0.5° (I > 0.1 A) <±1.5° (I ≤ 0.1 A)
Burden (50 Hz/60 Hz)	<0.1 VA
Coarse residual current input (I01)	
Rated current In	1 A (configurable 0.2 A to 10 A)
Thermal withstand	25 A continuous 100 A for 10 s 500 A for 1 s 1250 A for 0.01 s
Frequency measurement range	From 6 Hz to 75 Hz fundamental, up to 31st harmonic current

Current measurement range	5 mA to 150 A(RMS)
Current measurement inaccuracy	0.005 x In to 150 x In <math>\pm 0.5\%</math> or <math>\pm 3\text{ mA}</math>
Angle measurement inaccuracy	<math>\pm 0.5^\circ</math> (I > 0.05 A) <math>\pm 1.0^\circ</math> (I $\leq$ 0.05 A)
Burden (50 Hz/60 Hz)	<math>< 0.1\text{ VA}</math>
<b>Fine residual current input (I02)</b>	
Rated current In	0.2 A (configurable 0.2 A to 10 A)
Thermal withstand	25 A continuous 100 A for 10 s 500 A for 1 s 1250 A for 0.01 s
Frequency measurement range	From 6 Hz to 75 Hz fundamental, up to 31st harmonic current
Current measurement range	1 mA to 75 A (RMS)
Current measurement inaccuracy	$\pm 0.5\%$ or 0.6 mA whichever is smallest (0.005 x In to 25 x In) $\pm 1\%$ (25 x In to 375 x In)
Angle measurement inaccuracy	<math>\pm 1.0^\circ</math> (I > 0.05 A) <math>\pm 1.5^\circ</math> (I $\leq$ 0.05 A)
Burden (50 Hz/60 Hz)	<math>< 0.1\text{ VA}</math>
<b>Terminal block</b>	
Solid or stranded wire	Maximum wire diameter: 4 mm <sup>2</sup>
Phoenix Contact FRONT 4H-6,35	

- NOTE**
- Amplitude inaccuracy is  $\pm 0.5\%$  higher for frequencies  $f \neq 50$  or 60 Hz.
  - Angle inaccuracy is  $\pm 1.0^\circ$  higher for frequencies  $f \neq 50$  or 60 Hz, or  $U < 15\text{ V}$ .

## 4.3 Voltage measurement module

<b>Measurement channels/VT inputs</b>	
Total of four separate VT inputs	
<b>Voltage inputs (U1, U2, U3, U4)</b>	
Voltage measuring range	0.50 to 480.00 V (RMS)
Thermal withstand	630 V RMS continuous
Frequency measurement range	From 6 Hz to 75 Hz fundamental, up to 31st harmonic voltage
Voltage measurement inaccuracy	$\pm 1.5\%$ (1 V to 2 V) $\pm 0.5\%$ (2 V to 480 V)
Angle measurement inaccuracy	$\pm 0.5^\circ$ (15 to 480 V) $\pm 1.5^\circ$ (1 to 15 V)
Burden (50 Hz/60 Hz)	<math>< 0.02\text{ VA}</math>
<b>Terminal block</b>	
Solid or stranded wire	Maximum wire diameter: 4 mm <sup>2</sup>
Phoenix Contact PC 5% 8-STCL1-7.62	

- NOTE**
- Amplitude inaccuracy is  $\pm 0.5\%$  higher for frequencies  $f \neq 50$  or 60 Hz.
  - Angle inaccuracy is  $\pm 0.5^\circ$  higher for frequencies  $f \neq 50$  or 60 Hz.

## 4.4 Frequency, power and energy measurement accuracy

Frequency measurement	
Measuring range	6 to 75 Hz fundamental, up to 31st harmonic current and voltage
Inaccuracy	20 mHz
Power measurement P, Q, S	
Measuring range	Frequency range 6 to 75 Hz
Inaccuracy	<1.2 x In: 0.3 % or 3 VA of secondary, whichever is smallest >1.2 x In: 1.0 % or 3 VA of secondary, whichever is smallest
Energy measurement	
Measuring range	Frequency range 6 to 75 Hz
Energy and power metering inaccuracy	Class 0.5s (50/60 Hz according to IEC 62053-22) Class 0.2s (50/60 Hz according to IEC 62053-22) (option)

**NOTE** If one of the following criteria is fulfilled, then frequency inaccuracy is  $\pm 30$  mHz instead:

- $f \neq 50$  Hz or 60 Hz.
- Frequency tracking via voltages is applied.
- $U < 15$  V.

## 4.5 Digital inputs and outputs

### 4.5.1 Isolated digital inputs with software settable threshold (Option card B)

Rated auxiliary voltage	10 to 200 V DC <b>Caution:</b> When the working voltage is above 150 V AC, do not mix AC and DC voltage inside any relay groups or digital input groups.
Pick-up threshold	Software settable: 16 to 200 V DC, by step of 1 V
Release threshold	Software settable: 10 to 200 V DC, by step of 1 V
Pickup/release inaccuracy	@ 110 V DC/48 V DC: $\pm 5$ % of set point
Scanning rate	5 ms
Activation/release delay	5 to 11 ms
Pick-up delay	Software settable: 0 to 1800 s
Polarity	Software settable: Normally On/Normally Off
Typical current drain	2 mA
Terminal block	
Solid or stranded wire	Maximum wire diameter: 2.5 mm <sup>2</sup>
Phoenix Contact MSTB2,5-5,08	

**NOTE** See **Option B: Digital input module for MVR** for further information.

### 4.5.2 Normally open digital outputs (Option card C)

Rated auxiliary voltage	220 V AC 3 A (AC15) or 220 V DC 0.2 A (DC13) according to EN 60947-5-1
-------------------------	--



	<b>Caution:</b> When the working voltage is above 150 V AC, do not mix AC and DC voltage inside any relay groups or digital input groups.
Electrical rating	Max. 5 A
Thermal continuous rating @ 50 °C	Max. continuous carry 4 A
Make and carry 0.5 s Make and carry 3 s	30 A 15 A
Breaking capacity, DC (L/R = 40 ms): at 48 V DC at 110 V DC at 220 V DC	1 A 0.4 A 0.2 A
Control rate	5 ms
Polarity	Software settable: Normally On/Normally Off
Contact material	
<b>Terminal block</b>	
Solid or stranded wire	Maximum wire diameter: 2.5 mm <sup>2</sup>
Phoenix Contact MSTB2,5-5,08	

**NOTE** See **Option C: Relay output module for MVR** for further information.

#### 4.5.3 Isolated digital inputs (PSU card)

Rated auxiliary voltage	24, 110 or 220 V nominal <b>Caution:</b> When the working voltage is above 150 V AC, do not mix AC and DC voltage inside any relay groups or digital input groups.
Pick-up threshold (fixed)	Order code defined: 20, 90, 180 V
Release threshold (fixed)	Order code defined: 10, 60, 120 V
Scanning rate	5 ms
Pick-up delay	Software settable: 0 to 1800 s
Polarity	Software settable: Normally On/Normally Off
Typical current drain	2 mA
<b>Terminal block</b>	
Solid or stranded wire	Maximum wire diameter: 2.5 mm <sup>2</sup>
Phoenix Contact MSTB2,5-5,08	

#### 4.5.4 Changeover digital outputs (PSU card)

Rated auxiliary voltage	220 V AC 3 A (AC15) or 220 V DC 0.2 A (DC13) according to EN 60947-5-1 <b>Caution:</b> When the working voltage is above 150 V AC, do not mix AC and DC voltage inside any relay groups or digital input groups.
Electrical rating	Max. 5 A
Thermal continuous rating @ 50 °C	Max. continuous carry 4 A
Make and carry 0.5 s Make and carry 3 s	30 A 15 A
Breaking capacity, DC (L/R = 40 ms): at 48 V DC at 110 V DC at 220 V DC	1 A 0.4 A 0.2 A

Control rate	5 ms
Polarity	Software settable: Normally On/Normally Off
Contact material	
<b>Terminal block</b>	
Solid or stranded wire	Maximum wire diameter: 2.5 mm <sup>2</sup>
Phoenix Contact MSTB2,5-5,08	

## 4.6 Analogue outputs

### 4.6.1 Analogue output (option card I)

Output/measurement channels	Total of 5 analogue I/O: 4 x mA output and 1 x mA input
SlotX 1-2	0 to 24 mA outputs
SlotX 3-4	0 to 24 mA outputs
SlotX 5-6	0 to 24 mA outputs
SlotX 7-8	0 to 24 mA outputs
SlotX 9-10	0 to 24 mA input
Inaccuracy	0.5 % of full scale
<b>Terminal block</b>	
Solid or stranded wire	Maximum wire diameter: 4 mm <sup>2</sup>
Phoenix Contact PC 5% 8-STCL1-7.62	

**NOTE** See **Option I: Analogue I/O module for MVR** for further information.

## 4.7 Communication options

### 4.7.1 RS232 & Serial fiber communication module (Option card L to O)

**Table 4.1** RS232 & Serial fiber communication module technical data

Ports
RS232
Serial fiber (GG/PP/GP/PG)
Serial port wavelength
660 nm
Cable type
1 mm plastic fiber

**NOTE** See **Option L to O: Serial RS232 and Fiber module for MVR** for further information.

### 4.7.2 Double LC100 Mb Ethernet module (Redundant) (Option card J)

**Table 4.2** LC 100 Mbps Ethernet communication module technical data

Protocols	HSR and PRP
Sync	IEEE1588 (PIP) clock sync

Quantity of fiber ports	2
Communication port C & D	LC fiber connector Wavelength 1300 nm Configurable to 10 Mbps or 100 Mbps
Fiber cable	50/125 µm or 62.5/125 µm multi-mode (glass)

**NOTE** See **Option J: 100 MB fiber Ethernet module for MVR** for further information.

## 4.8 Communication ports

Front panel local communication port	
Port, media	Ethernet RJ-45, Copper
Number of ports	1
Port protocols	PC-protocols, FTP, Telnet
Data transfer rate	100 MB
System integration	Cannot be used for system protocols, only for local programming
Rear panel system communication port A	
Port, media	Ethernet RJ-45, Copper
Number of ports	1
Port protocols	Modbus TCP, DNP 3.0, FTP, Telnet
Data transfer rate	100 MB
System integration	Can be used for system protocols and for local programming
Rear panel system communication port B	
Port, media	RS-485, Copper
Number of ports	1
Port protocols	Modbus RTU, DNP 3.0, IEC-103
Data transfer rate	65580 kB/s
System integration	Can be used for system protocols

**NOTE** See **Option J 100 MB fiber Ethernet module for MVR** for further information.

## 4.9 MVR-21x display

### 4.9.1 Display

**Table 4.3** HMI LCD display technical data

Dimensions and resolution	
Number of dots / resolution	320 x 160
Size	84.78mm × 49.90mm
Display	
Type of display	LCD
Color	Monochrome

## 4.10 MVR-25x display

### 4.10.1 Display

**Table 4.4** HMI TFT display technical data



Dimensions and resolution	
Number of dots / resolution	800 x 480
Size	7 inches
Display	
Type of display	TFT
Color	RGB color

## 4.11 Folios and configuration

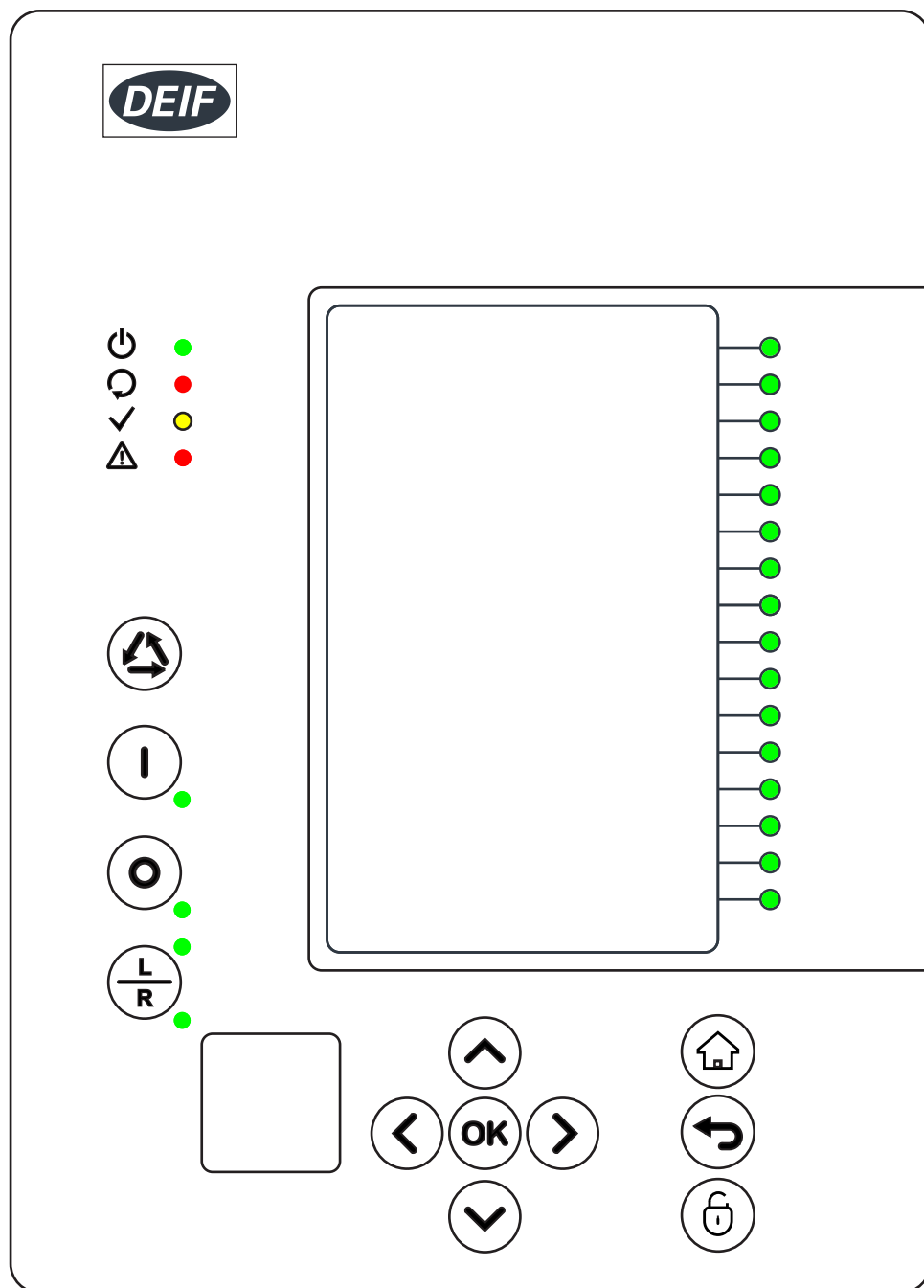
### MVR-21x folio



To meet marine class society requirements:

- The MVR must be configured so that the **Trip LED** (   ) is lit whenever a protection activates a breaker trip.
- For each trip protection, select *Trip ON* in the NOC EventMask. In this way, the cause of any trip is shown on the main screen and immediately visible to the operator.

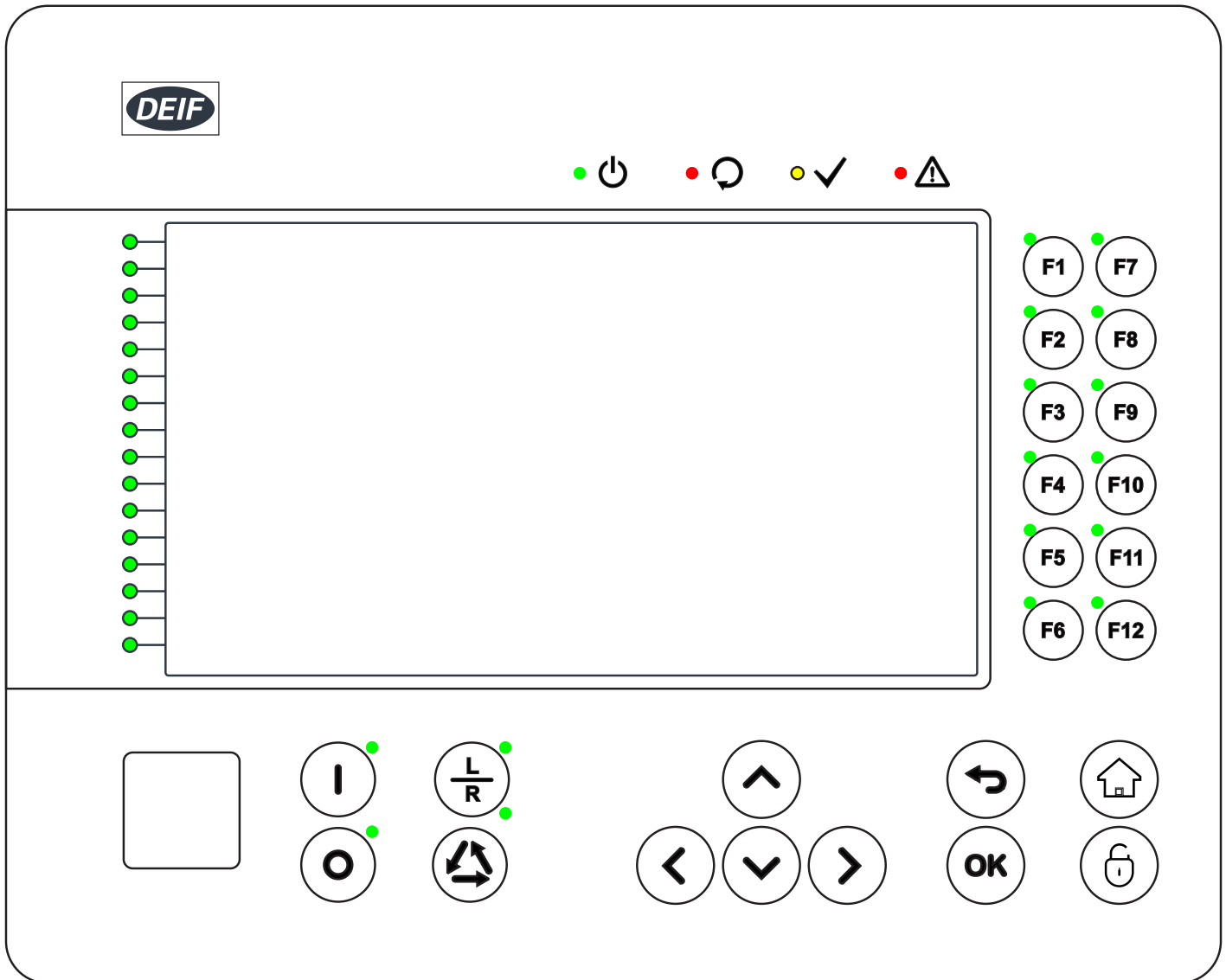

To meet marine class society requirements:

- The MVR must be configured so that the **Trip LED** ( ● ⚠ ) is lit whenever a protection activates a breaker trip.
- For each trip protection, select *Trip ON* in the NOC EventMask. In this way, the cause of any trip is shown on the main screen and immediately visible to the operator.
- Alarm LED colours must be configured as follows:

Alarm state	Details	LED colour
OK	There is no alarm.	Green
Warning	There is an alert for the operator, but no alarm action.	Yellow ( <i>Orange</i> )
Trip or Fault	The controller has sent a trip signal the breaker.	Red

## 4.12 Mechanical specifications

Device dimensions	210 series casing height 250 series casing height	¼ rack 4U, depth 210 mm 208 mm, width 257 mm, depth 210 mm
Package dimensions (W x H x D)	210 series 250 series	230 x 120 x 210 mm 345 x 240 x 258 mm

Weight	Device	1.5 kg
	In package	2.0 kg
Material	Housing	Metal
IP protection level	Front	IP54
	Rear	IP20
Tightening torque - M4 nuts	Front	1.3 N·m for 210 series 1.1 N·m for 250 series

## 4.13 Environment

IEC 60255-27 degree of pollution	2
Maximum altitude above sea level	2000 m (6561.68 ft)
Operation temperature range	-25 °C to +60 °C

## 4.14 Safety

### Wiring specification

Wiring must be multi-stranded, minimum 90 °C copper conductors only.

### Galvanic isolation

Ethernet: 550 V, 50 Hz, 1 minute

COM ports: 550 V, 50 Hz, 1 minute

Between Option I (mA I/O) and other I/O ports: 550 V, 50 Hz, 1 minute

Between CT and other I/O ports: 2200 V, 50 Hz, 1 minute

Between Relay and other I/O ports: 2200 V, 50 Hz, 1 minute

Between DI and other I/O ports: 2200 V, 50 Hz, 1 minute

Between PSU and other I/O ports: 2200 V, 50 Hz, 1 minute

## 4.15 Dimensions

Figure 4.1 MVR-210 dimensions

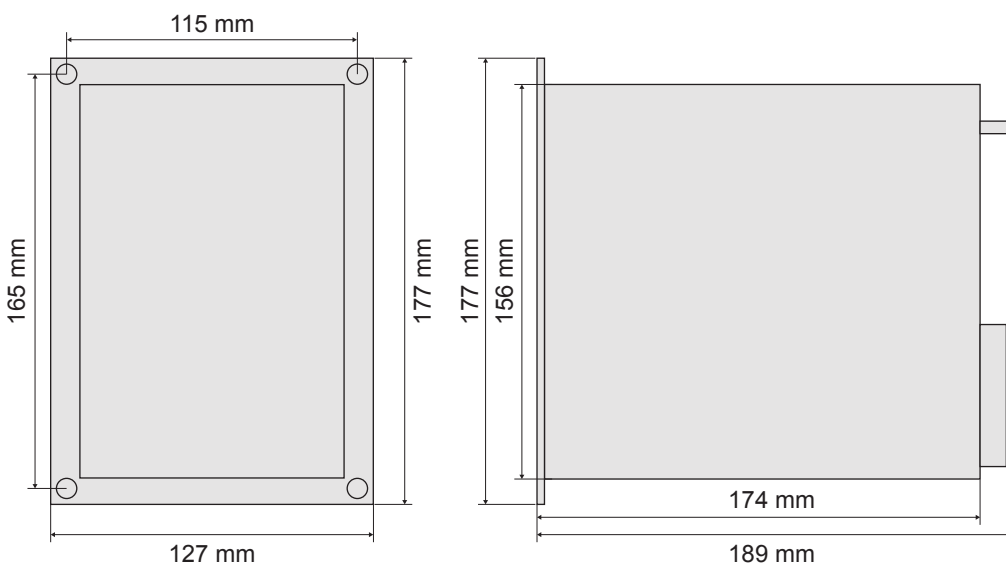

**Figure 4.2** MVR-250 dimensions

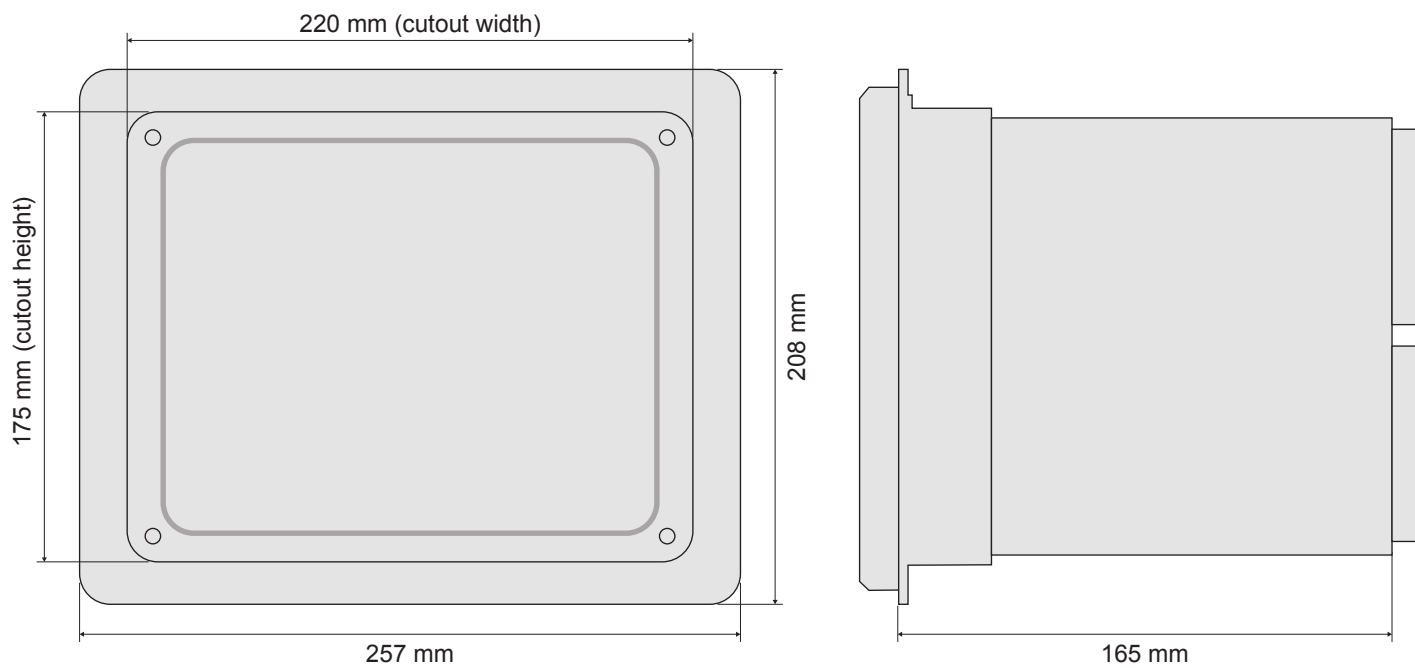



# 5. Ordering information

## 5.1 MVR Ordering

The drawings show the rear view of the MVR series without hardware options.

### MVR Feeder relay MVR-F201/205

MVR-F20  -P  8  A  A

- A: 3 DI 24 V on processor module
- B: 3 DI 110 V on processor module
- C: 3 DI 220 V on processor module

- A: Standard AC current terminal block
- B: Ring lug AC current terminal block

- H: 100-125 V DC Aux. Voltage
- L: 24-48 V DC Aux. Voltage

- 1: 5 AC current inputs
- 5: 5 AC current inputs + 4 AC voltage inputs

MVR-F201

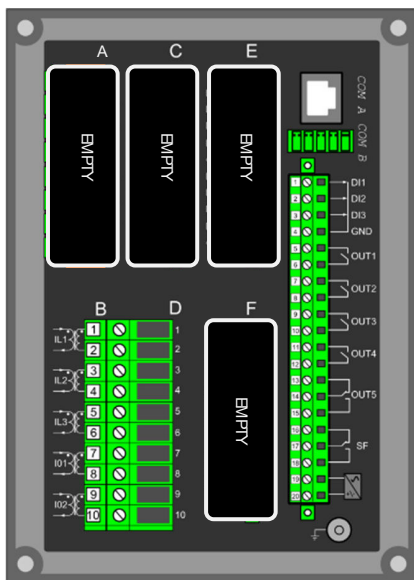

MVR-F205

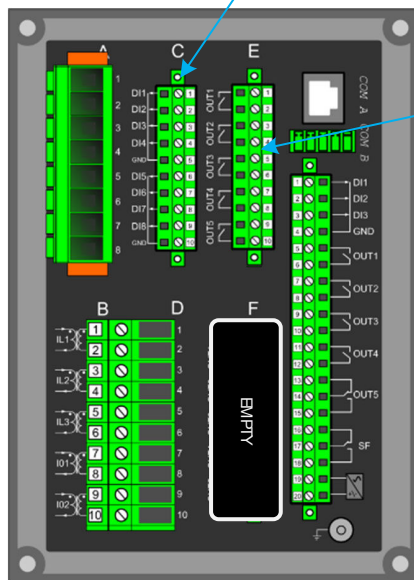

8 x DI

5 x Relay out

### MVR Feeder/Motor relay MVR-210

MVR-  210-P  8  A  A -

- Slot F option (see hardware overview)
- Slot E option (see hardware overview)
- Slot C option (see hardware overview)
- Slot A option (see hardware overview)

- A: 3 DI 24 V on processor module
- B: 3 DI 110 V on processor module

- A: Standard AC current terminal block
- B: Ring lug AC current terminal block

- H: 100-125 V DC Aux. Voltage
- L: 24-48 V DC Aux. Voltage

- F: Feeder
- M: Motor

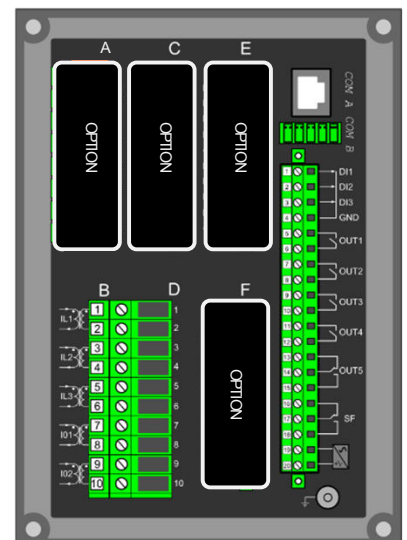

## MVR Busbar relay MVR-V211

MVR-V211-□-P □ 8 □ A □ A - □ □ □ □ □

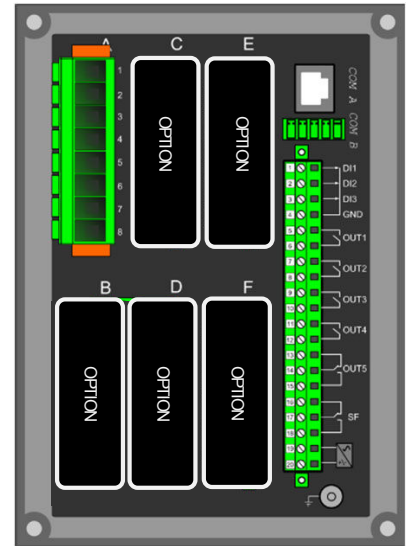
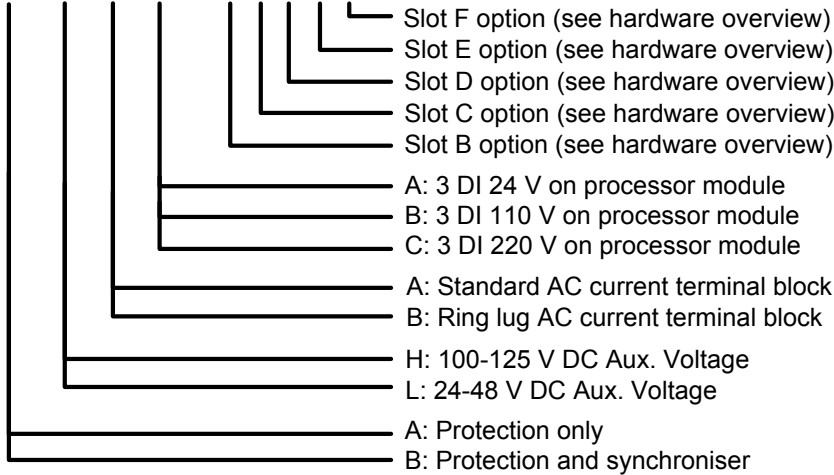

## MVR Feeder/Generator/Transformer/Motor relay MVR-215

MVR-□215-P □ □ □ A □ A - □ □ □

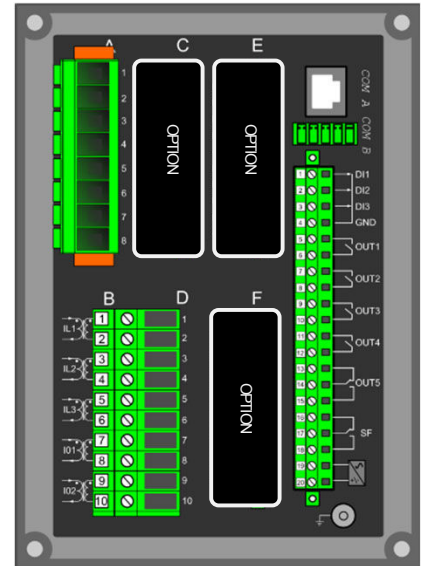
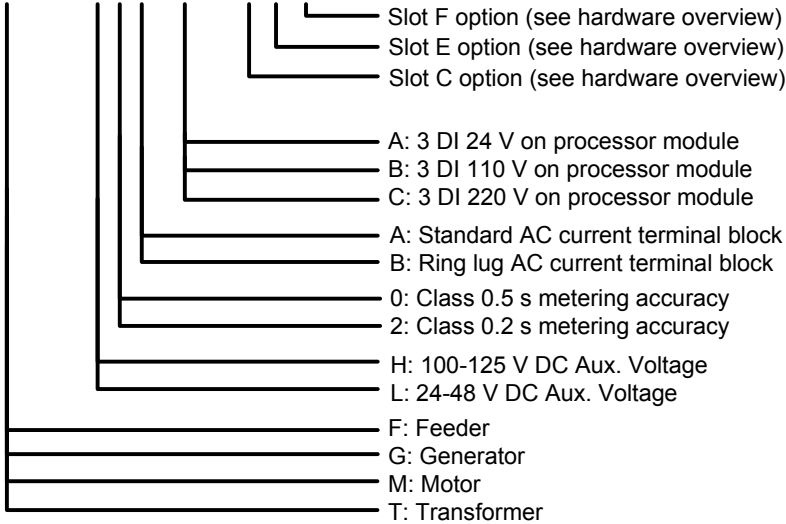

## MVR Transformer relay MVR-T216

MVR-T216-P □ 8 □ A □ A - □ □

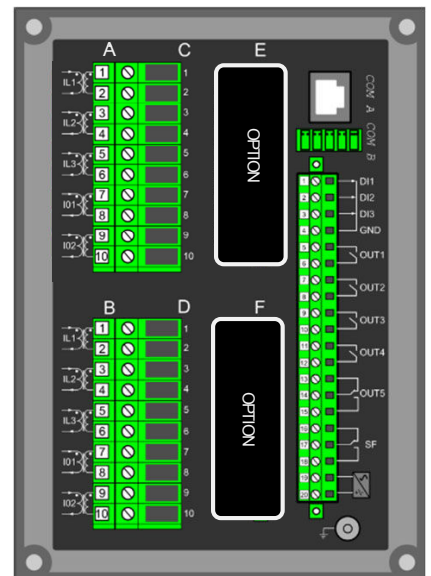
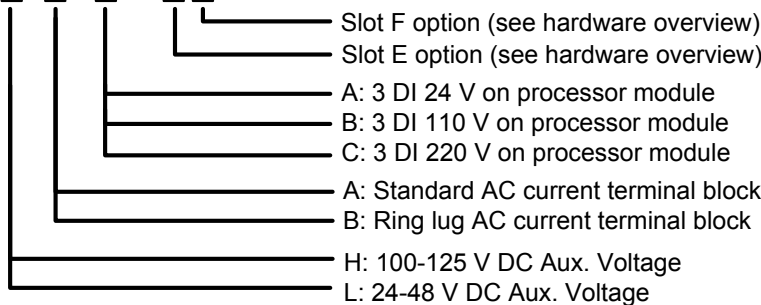

# MVR Feeder/Motor relay MVR-255

MVR-□255-P □□□A□A - □□□□□□□□□□□□□□□□

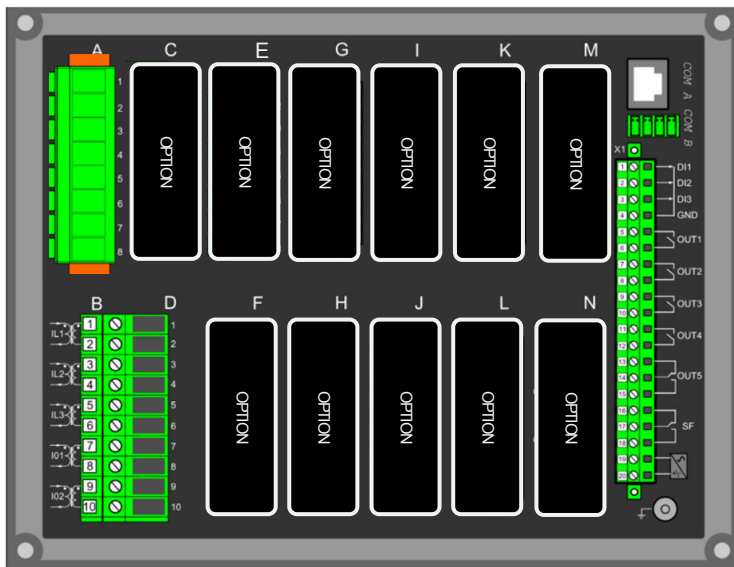
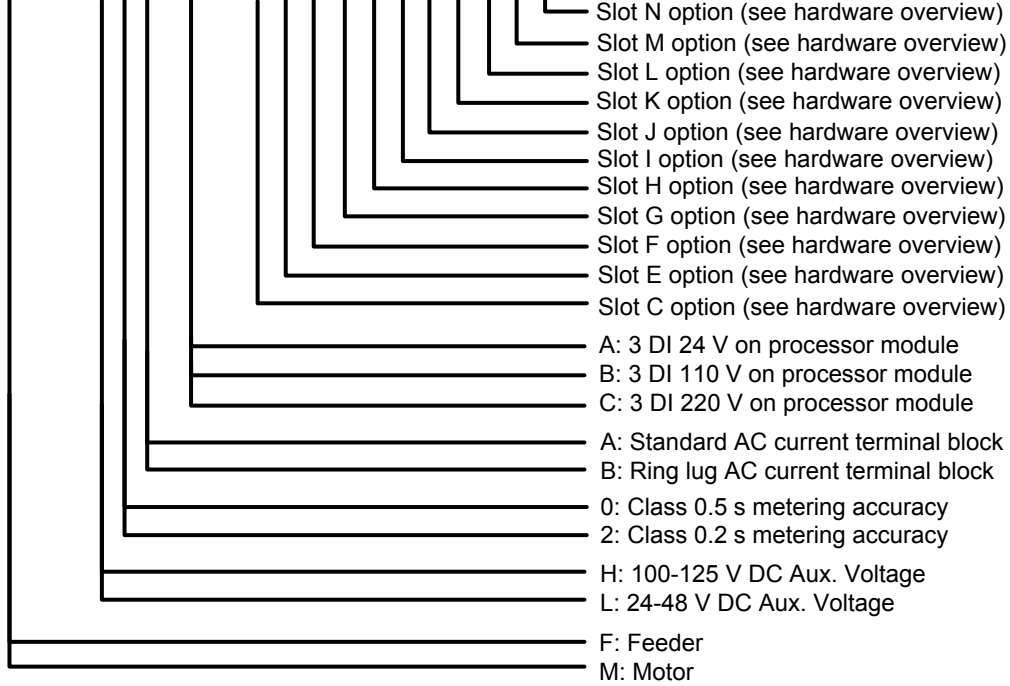

# MVR Transformer relay MVR-T256

MVR- T256-P 8 A A -

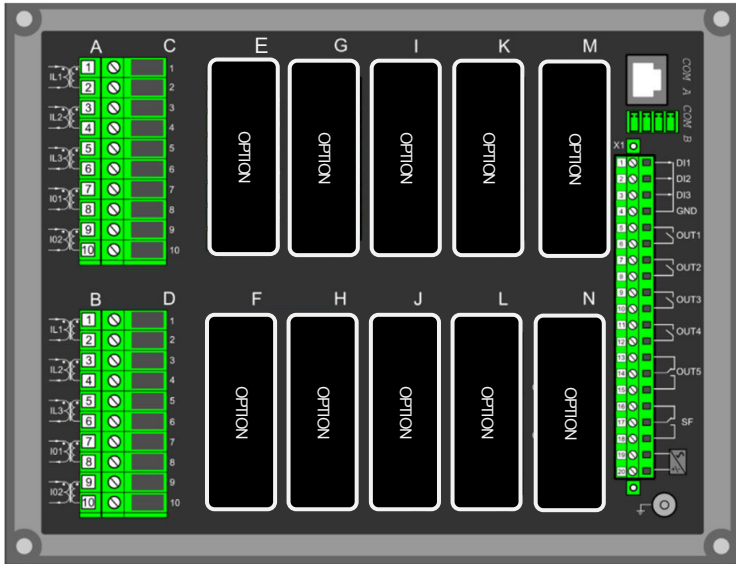
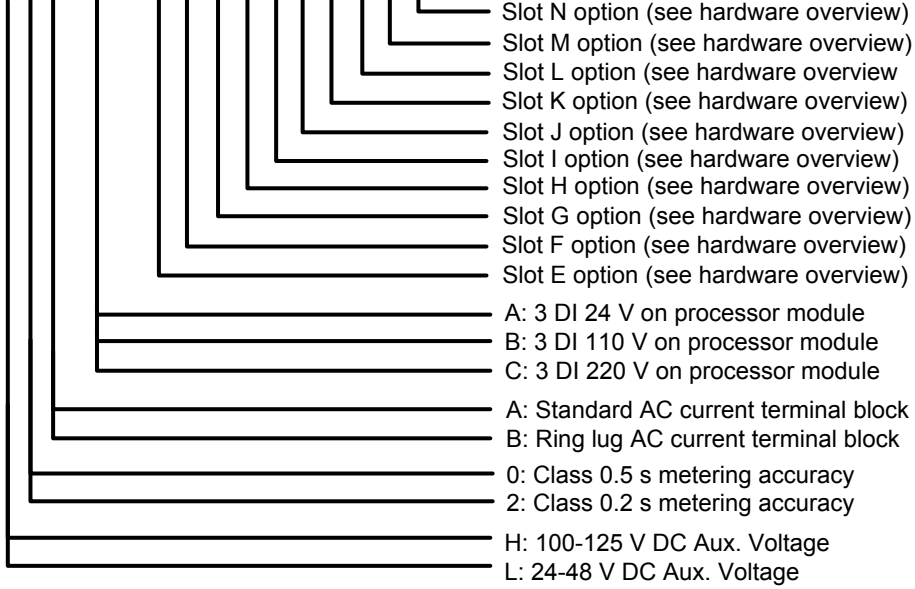

## MVR Generator/Motor/Transformer relay MVR-257

MVR-□257□-□□□A□A - □□□□□□□□□□

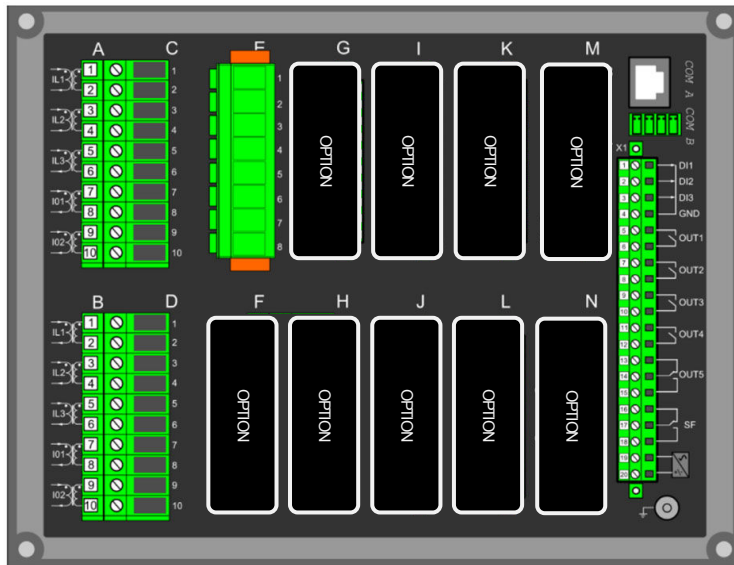
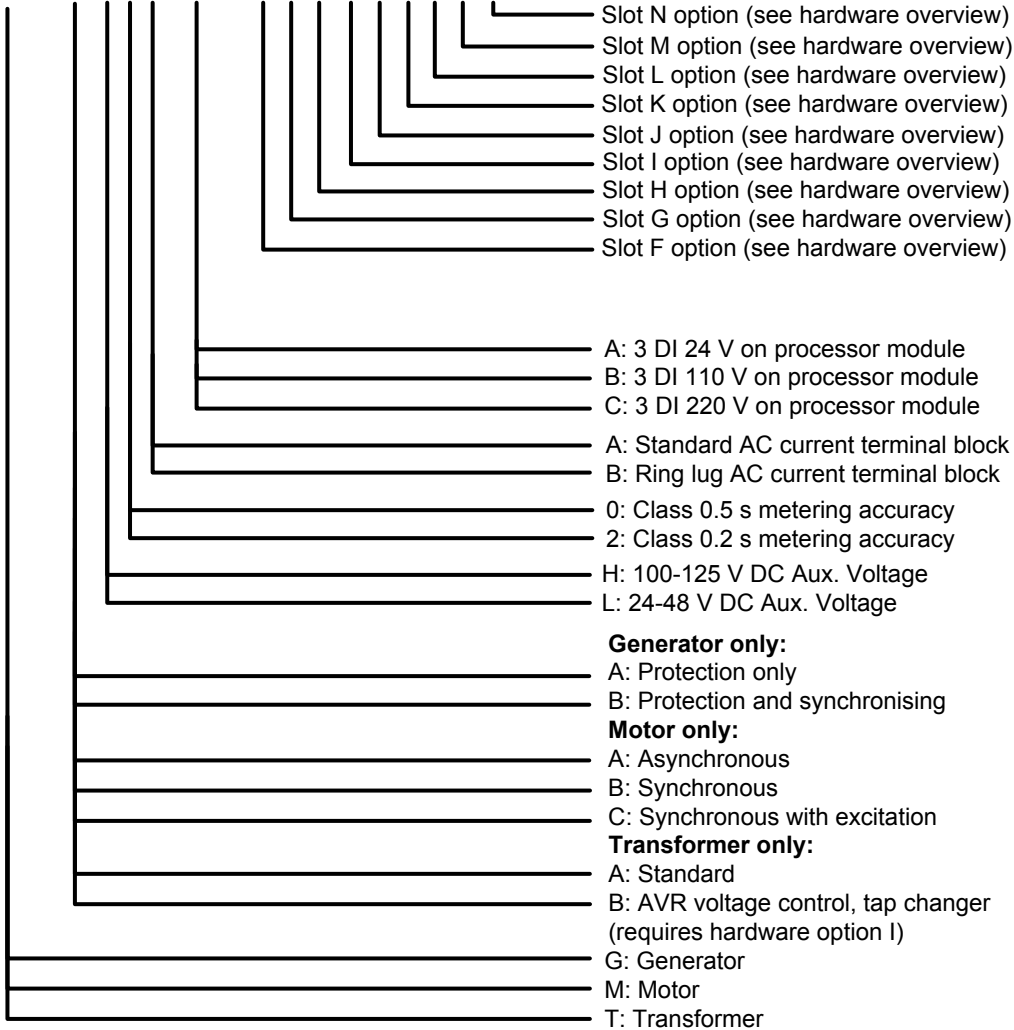

## MVR Hardware Options overview

Option	Hardware module
A	No option (empty slot)
B	8 x isolated (2 groups) digital inputs <ul style="list-style-type: none"> <li>• 10 to 200 V DC</li> </ul>

Option	Hardware module
<b>C</b>	5 x NO relay outputs <ul style="list-style-type: none"> <li>• 220 V AC, 3 A</li> <li>• 220 V DC, 0.3 A</li> </ul>
<b>D</b>	Reserved (not used)
<b>E</b>	Reserved (not used)
<b>F</b>	Reserved (not used)
<b>G</b>	Reserved (not used)
<b>H</b>	Reserved (not used)
<b>I</b>	4 x analogue outputs <ul style="list-style-type: none"> <li>• 0 to 24 mA scalable</li> </ul> 1 x analogue input <ul style="list-style-type: none"> <li>• 0 to 24 mA scalable</li> </ul> Max. 2 modules per relay
<b>J</b>	2 x Fiber Ethernet*
<b>L</b>	1 x RS232 Fiber PP (Plastic-Plastic)*
<b>M</b>	1 x RS232 Fiber PG (Plastic-Glass)*
<b>N</b>	1 x RS232 Fiber GP (Glass-Plastic)*
<b>O</b>	1 x RS232 Fiber GG (Glass-Glass)*

**NOTE** \* Only one communication module per relay, to be placed in the last slot.

- MVR- 21x series: Slot F
- MVR- 25x series: Slot N

## 5.2.1 Disclaimer

DEIF A/S reserves the right to change any of the contents of this document without prior notice.

The English version of this document always contains the most recent and up-to-date information about the product. DEIF does not take responsibility for the accuracy of translations, and translations might not be updated at the same time as the English document. If there is a discrepancy, the English version prevails.

## 5.2.2 Copyright

© Copyright DEIF A/S 2020. All rights reserved.