



AGC 150



1. Introduction

1.1 About the installation instructions	3
1.1.1 General purpose	3
1.1.2 Intended users of the Installation instructions	3
1.1.3 List of technical documentation for AGC 150	3
1.2 Warnings and safety	4
1.2.1 Safety during installation and operation	4
1.2.2 Disable the breakers and the engine start	4
1.2.3 Factory settings	4
1.2.4 Electrostatic discharge	4
1.2.5 Data security	4
1.3 Legal information	5
1.3.1 Third party equipment	5
1.3.2 Warranty	5
1.3.3 Disclaimer	5
1.3.4 Copyright	5

2. Product description

2.1 General description	6
2.1.1 General description	6
2.1.2 Controller types	6

3. Mounting

3.1 AGC 150 mounting and dimensions	7
3.1.1 Dimensions	7
3.1.2 Tools and materials	8
3.1.3 Mounting instructions	8

4. Hardware

4.1 AGC 150 hardware	9
4.1.1 Rear side connections	9

5. Wiring

5.1 Wiring overview	13
5.1.1 Wiring overview	13
5.2 AC connections	15
5.2.1 AC connections	15
5.2.2 I4 current	17
5.2.3 Current transformer ground	18
5.2.4 Voltage measurement fuses	18
5.2.5 Analogue inputs	18
5.3 DC connections	20
5.3.1 Digital inputs	20
5.3.2 Digital outputs	20
5.3.3 Breaker wiring	21
5.3.4 Power supply and start	22
5.4 Communication	22
5.4.1 CAN bus power management system	22
5.4.2 CAN bus engine communication	23
5.4.3 Modbus RS-485	23

1. Introduction

1.1 About the installation instructions

1.1.1 General purpose

These are the Installation instructions for DEIF's Advanced Genset Controller, AGC 150. The Installation instructions provide information for the correct installation of the controller, with primary focus on the physical installation of the equipment.



DANGER!

Read these instructions before installation of the AGC 150 controller, to avoid personal injury and damage to the equipment.

1.1.2 Intended users of the Installation instructions

The Installation instructions are primarily intended for the people, who mount and wire up the controller. Designers may find it useful to refer to the Installation instructions, when developing the system's wiring diagrams, and operators may find it useful to refer to the Installation instructions while troubleshooting.

1.1.3 List of technical documentation for AGC 150

Document	Contents
Product sheet	<ul style="list-style-type: none">• Short description• Controller applications• Main features and functions• Technical data• Protections• Dimensions
Data sheet	<ul style="list-style-type: none">• General description• Functions and features• Controller applications• Controller types and variants• Protections• Inputs and outputs• Technical specifications
Designer's handbook	<ul style="list-style-type: none">• Principles• General controller sequences, functions and protections• GENSET controller• Mains controller• BTB controller• Hybrid controller• Protections and alarms• AC configuration and nominal settings• Breaker and synchronisation• Regulation• Load sharing• Hardware characteristics• Modbus
Installation instructions	<ul style="list-style-type: none">• Tools and materials

Document	Contents
	<ul style="list-style-type: none"> • Mounting • Minimum wiring for the controller • Wiring communication
Operator's manual	<ul style="list-style-type: none"> • Controller equipment (buttons and LEDs) • Operating the system • Alarms • Log
Modbus tables	<ul style="list-style-type: none"> • Modbus address list <ul style="list-style-type: none"> ◦ PLC addresses ◦ Corresponding controller functions • Descriptions for function codes, function groups

1.2 Warnings and safety

1.2.1 Safety during installation and operation

Installing and operating the controller may require work with dangerous currents and voltages. The installation must only be carried out by authorised personnel who understand the risks involved in working with electrical equipment.



DANGER!

Hazardous live currents and voltages. Do not touch any terminals, especially the AC measurement inputs and the relay terminals. Touching the terminals could lead to injury or death.

1.2.2 Disable the breakers and the engine start

Disconnect or disable the breakers **before** connecting the controller power supply. Do not enable the breakers until **after** the wiring and controller operation are thoroughly tested.



DANGER!

Unintended breaker closing can cause deadly and/or dangerous situations.

Disconnect or disable or block the engine start **before** connecting the controller power supply. Do not enable the engine start until **after** the wiring and controller operation are thoroughly tested.



DANGER!

Unintended engine starts can cause deadly and/or dangerous situations.

1.2.3 Factory settings

The controller is delivered pre-programmed from the factory with a set of default settings. These settings are based on typical values and may not be correct for your system. You must therefore check all parameters before using the controller.

1.2.4 Electrostatic discharge

Electrostatic discharge can damage the controller terminals. You must protect the terminals from electrostatic discharge during the installation. When the controller is installed and connected, these precautions are no longer necessary.

1.2.5 Data security

To minimise the risk of data security breaches DEIF recommends to:

- As far as possible, avoid exposing controllers and controller networks to public networks and the Internet.

- Use additional security layers like a VPN for remote access, and install firewall mechanisms.
- Restrict access to authorised persons.

1.3 Legal information

1.3.1 Third party equipment

DEIF takes no responsibility for the installation or operation of any third party equipment, including the **genset**. Contact the **genset company** if you have any doubt about how to install or operate the genset.

1.3.2 Warranty



CAUTION

The AGC 150 controller is not to be opened by unauthorised personnel. If opened anyway, the warranty will be lost.

1.3.3 Disclaimer

DEIF A/S reserves the right to change any of the contents of this document without prior notice.

The English version of this document always contains the most recent and up-to-date information about the product. DEIF does not take responsibility for the accuracy of translations, and translations might not be updated at the same time as the English document. If there is a discrepancy, the English version prevails.

1.3.4 Copyright

© Copyright DEIF A/S 2020. All rights reserved.

2. Product description

2.1 General description

2.1.1 General description

AGC 150 is a controller containing all necessary functions for protection and control of a genset, a mains breaker, and a bus tie breaker. It can be used as a single controller for one genset, or a number of controllers can be connected in a complete power management system for synchronising projects, island applications or running parallel to mains.

AGC 150 is an economical solution for genset builders, who need a flexible generator protection and controller for small to large genset applications.

AGC 150 contains all necessary 3-phase measuring circuits, and all values and alarms are presented on the sunlight readable LCD display screen.

2.1.2 Controller types

The AGC 150 controller comes in four different types.

Select the controller type under **Settings > Basic settings > Controller settings > Type**.

Parameter no.	Controller type	Device type
9101	Genset controller	DG unit
	Mains controller	Mains unit
	BTB controller	BTB unit
	Hybrid controller	DG Hybrid unit

3. Mounting

3.1 AGC 150 mounting and dimensions

3.1.1 Dimensions and weight

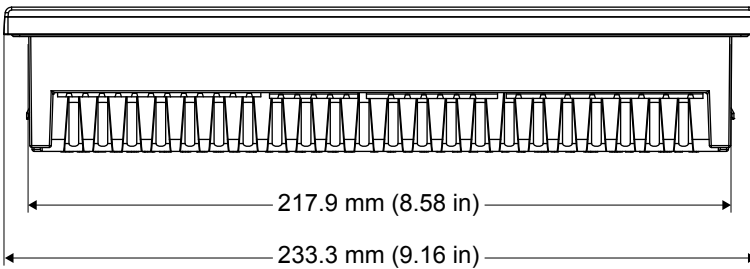
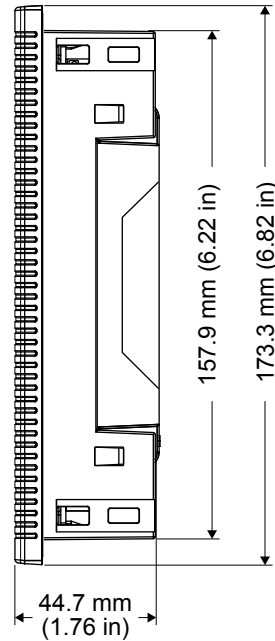
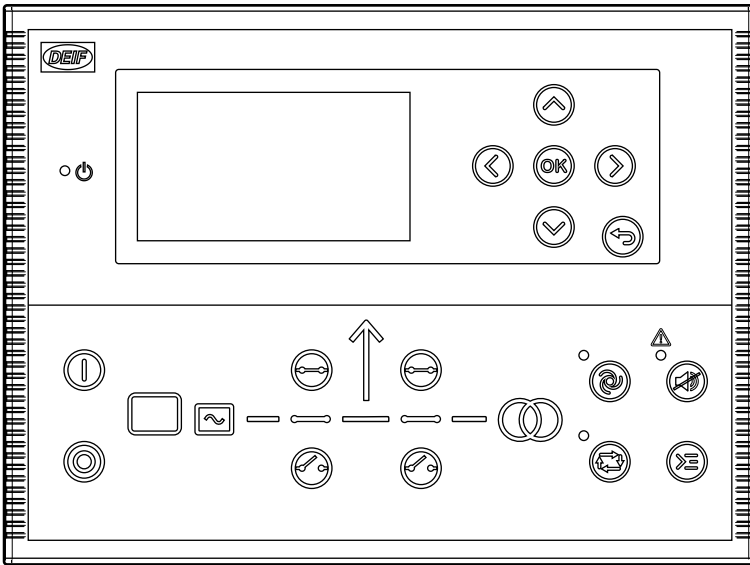

Dimensions and weight

Dimensions	Length: 233.3 mm (9.16 in) Height: 173.3 mm (6.82 in) Depth: 44.7 mm (1.76 in)
Panel cutout	Length: 218.5 mm (8.60 in) Height: 158.5 mm (6.24 in) Tolerance: ± 0.3 mm (0.01 in)
Max. panel thickness	4.5 mm (0.18 in)
Mounting	UL/cUL Listed: Type complete device, open type 1 UL/cUL Listed: For use on a flat surface of a type 1 enclosure
Weight	0.79 kg

3.1.2 Tools and materials

Tools required for mounting

Tool	Used for
Safety equipment	Personal protection, according to local standards and requirements
Screwdriver, PH2 or 5 mm flat	Tighten the fixing screw clamps, torque 0.15 N·m (1.3 lb-in)
Wire stripper, pliers and cutters	Prepare wiring and trim cable ties



CAUTION

Do not use power tools during the installation. Too much torque will damage the the screw clamps and/or the controller housing.

Materials required for mounting and wiring

Materials	Used for
Four screw clamps	Mounting the controller in the front panel
Wires and connectors	Wiring third party equipment to the controller terminals
Ethernet cable	Connecting the controller communication between controllers and/or external systems
Cable ties	Securing wiring and Ethernet cable

3.1.3 Mounting instructions

The controller is designed for mounting in the panel front. Max. panel thickness: 4.5 mm (0.18 in).

Panel cutout:

- Width: 218.5 mm (8.60 in)
- Height: 158.5 mm (6.24 in)
- Tolerance: ± 0.3 mm (0.01 in)

1. Insert the controller in the panel.
2. Insert the screw clamps:

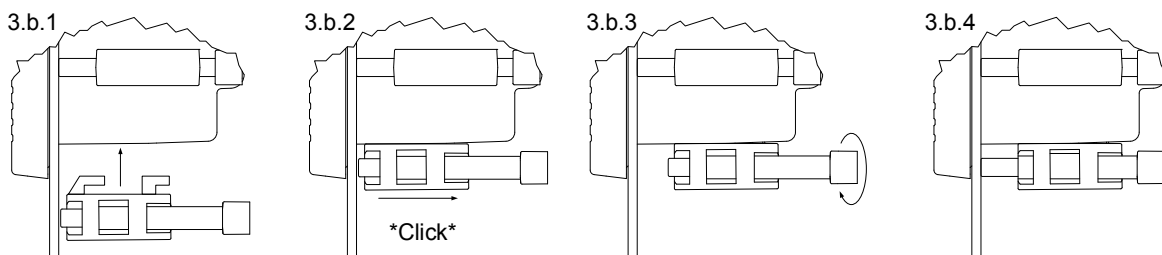

3. Tighten the screw clamps to 0.2 Nm.

4. Hardware

4.1 AGC 150 hardware

4.1.1 Rear side connections

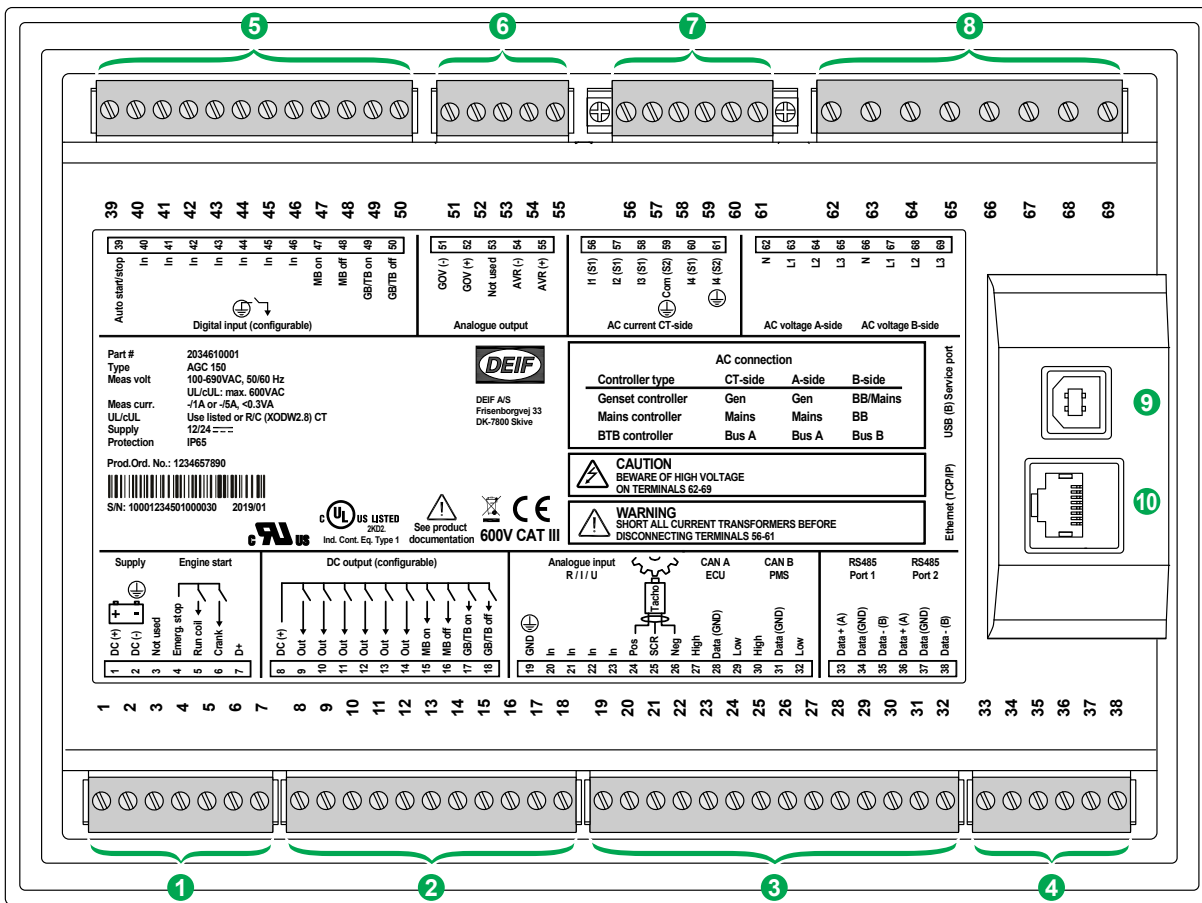

Table 4.1 Plug 1: Supply/Engine start

Terminal	Text	Function	Technical data
1	Supply, DC (+)	+12/24 V DC	6.5 to 36 V DC
2	Supply, DC (-)	0 V DC	
3	Not used	-	-
4	Emerg. stop	Digital input and supply for terminals 5, 6 and 7	
5	Run coil	Configurable	Max. 3 A
6	Crank	Configurable	Max. 3 A
7	D+		See data sheet for technical data

Table 4.2 Plug 2: DC output

Terminal	Text	Function	Technical data
8	Digital output supply, DC (+)		
9	Out	Configurable	Max. 500 mA

Terminal	Text	Function	Technical data
10	Out	Configurable	Max. 500 mA
11	Out	Configurable	Max. 500 mA
12	Out	Configurable	Max. 500 mA
13	Out	Configurable	Max. 500 mA
14	Out	Configurable	Max. 500 mA
15	MB on	Configurable (application dependent)	Max. 500 mA
16	MB off	Configurable (application dependent)	Max. 500 mA
17	GB/TB on	Configurable (application dependent), also used for BTB ON	Max. 500 mA
18	GB/TB off	Configurable (application dependent), also used for BTB OFF	Max. 500 mA

Table 4.3 Plug 3: Analogue input/MPU/CANbus

Terminal	Text	Function	Technical data
19	GND	Common	Must be grounded to Engine GND
20	In	Analogue input R/I/U	
21	In	Analogue input R/I/U	
22	In	Analogue input R/I/U	
23	In	Analogue input R/I/U	
24	Pos.	Tacho	
25	SCR	Tacho	
26	Neg	Tacho	
27	High	CAN A ECU	Not isolated
28	Data (GND)	CAN A ECU	Not isolated
29	Low	CAN A ECU	Not isolated
30	High	CAN B PMS	Isolated
31	Data (GND)	CAN B PMS	Isolated
32	Low	CAN B PMS	Isolated

Table 4.4 Plug 4: RS-485

Terminal	Text	Function	Technical data
33	Data + (A)	RS-485-1	Isolated
34	Data (GND)	RS-485-1	Isolated
35	Data - (B)	RS-485-1	Isolated
36	Data + (A)	RS-485-2	Not isolated
37	Data (GND)	RS-485-2	Not isolated
38	Data - (B)	RS-485-2	Not isolated

Table 4.5 Plug 5: Digital input

Terminal	Text	Function	Technical data
39	In	Configurable	Negative switching only, < 100 Ω
40	In	Configurable	Negative switching only, < 100 Ω
41	In	Configurable	Negative switching only, < 100 Ω
42	In	Configurable	Negative switching only, < 100 Ω
43	In	Configurable	Negative switching only, < 100 Ω
44	In	Configurable	Negative switching only, < 100 Ω
45	In	Configurable	Negative switching only, < 100 Ω
46	In	Configurable	Negative switching only, < 100 Ω
47	MB on	Configurable (application dependent)	Negative switching only, < 100 Ω
48	MB off	Configurable (application dependent)	Negative switching only, < 100 Ω
49	GB/TB on	Configurable (application dependent), also used for BTB ON	Negative switching only, < 100 Ω
50	GB/TB off	Configurable (application dependent), also used for BTB OFF	Negative switching only, < 100 Ω

Table 4.6 Plug 6: Analogue output

Terminal	Text	Function	Technical data
51	GOV (-)	Voltage or PWM output	Isolated
52	GOV (+)	Voltage or PWM output	Isolated
53	Not used	-	-
54	AVR (-)	Voltage output	Isolated
55	AVR (+)	Voltage output	Isolated

Table 4.7 Plug 7: AC current CT-side

Terminal	Text	Function	Technical data
56	L1 (S1)		
57	L2 (S1)		
58	L3 (S1)		
59	Com (S2)	Common	Must be connected to frame GND
60	L4 (S1)	Neutral, Earth or Mains/Tie power	
61	L4 (S2)	Neutral, Earth or Mains/Tie power	Must be connected to frame GND

Table 4.8 Plug 8: AC voltage measurement

Terminal	Text	Function	Technical data
62	N	A-side	
63	L1	A-side	
64	L2	A-side	
65	L3	A-side	

Terminal	Text	Function	Technical data
66	N	B-side	
67	L1	B-side	
68	L2	B-side	
69	L3	B-side	

Table 4.9 Plug 9: PC connection

Description	Function	Technical data
USB connection	Service port	USB B

Table 4.10 Plug 9: Modbus connection

Description	Function	Technical data
RJ45	Modbus TCP/IP connection	Ethernet

5. Wiring

5.1 Wiring overview

5.1.1 Wiring overview

Figure 5.1 Typical wiring for genset

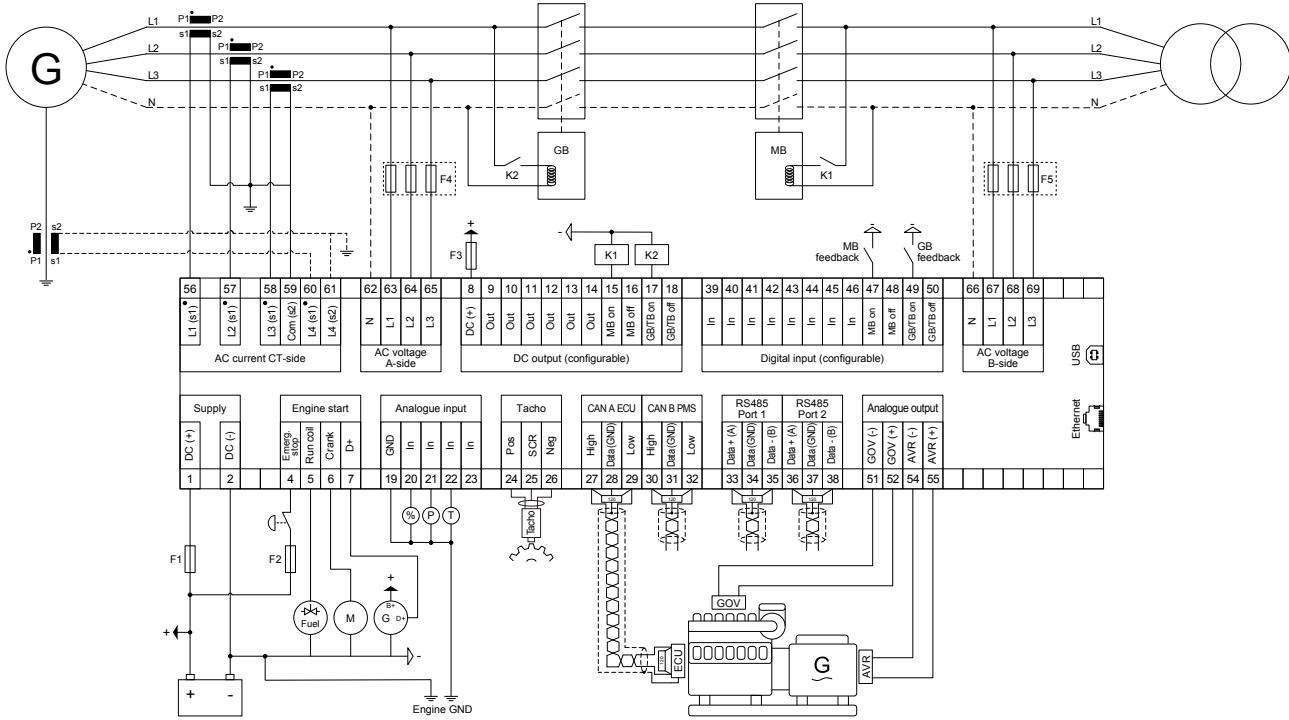

Figure 5.2 Typical wiring for mains

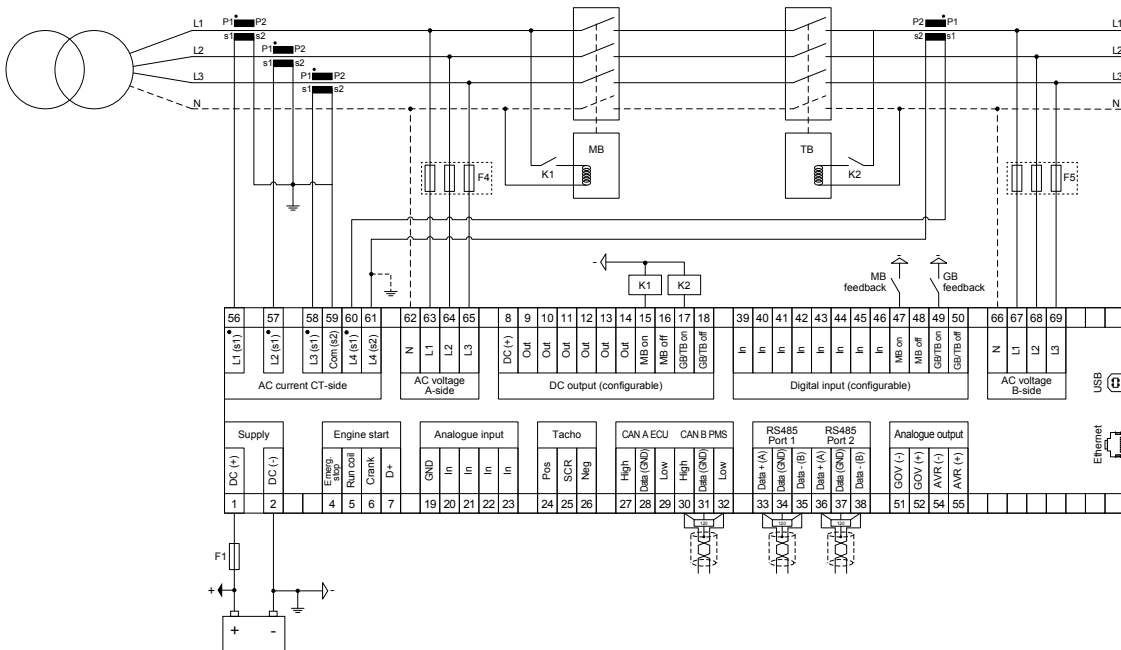

Figure 5.3 Typical wiring for BTB

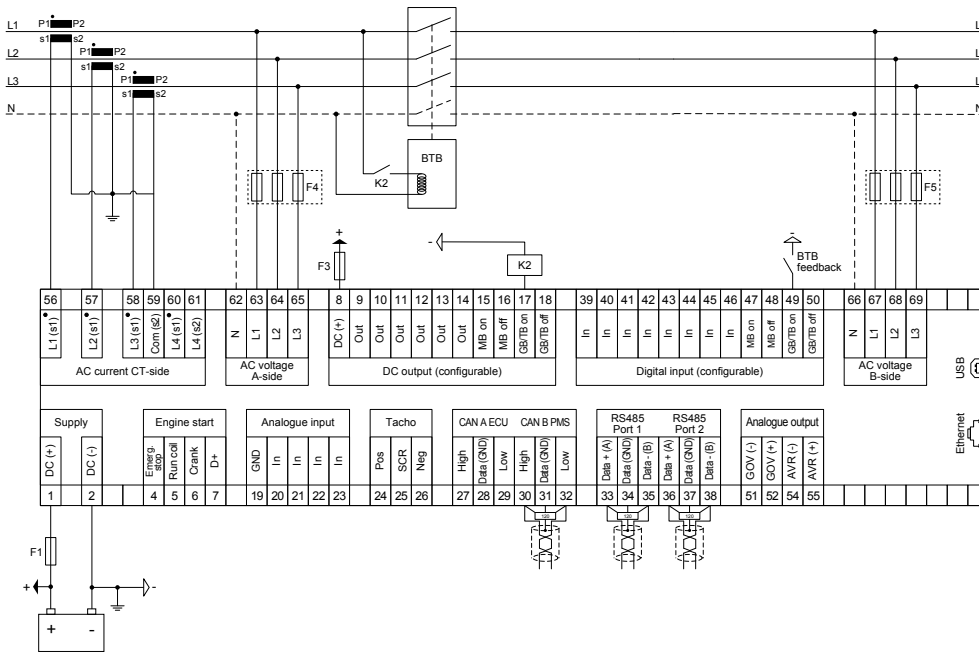
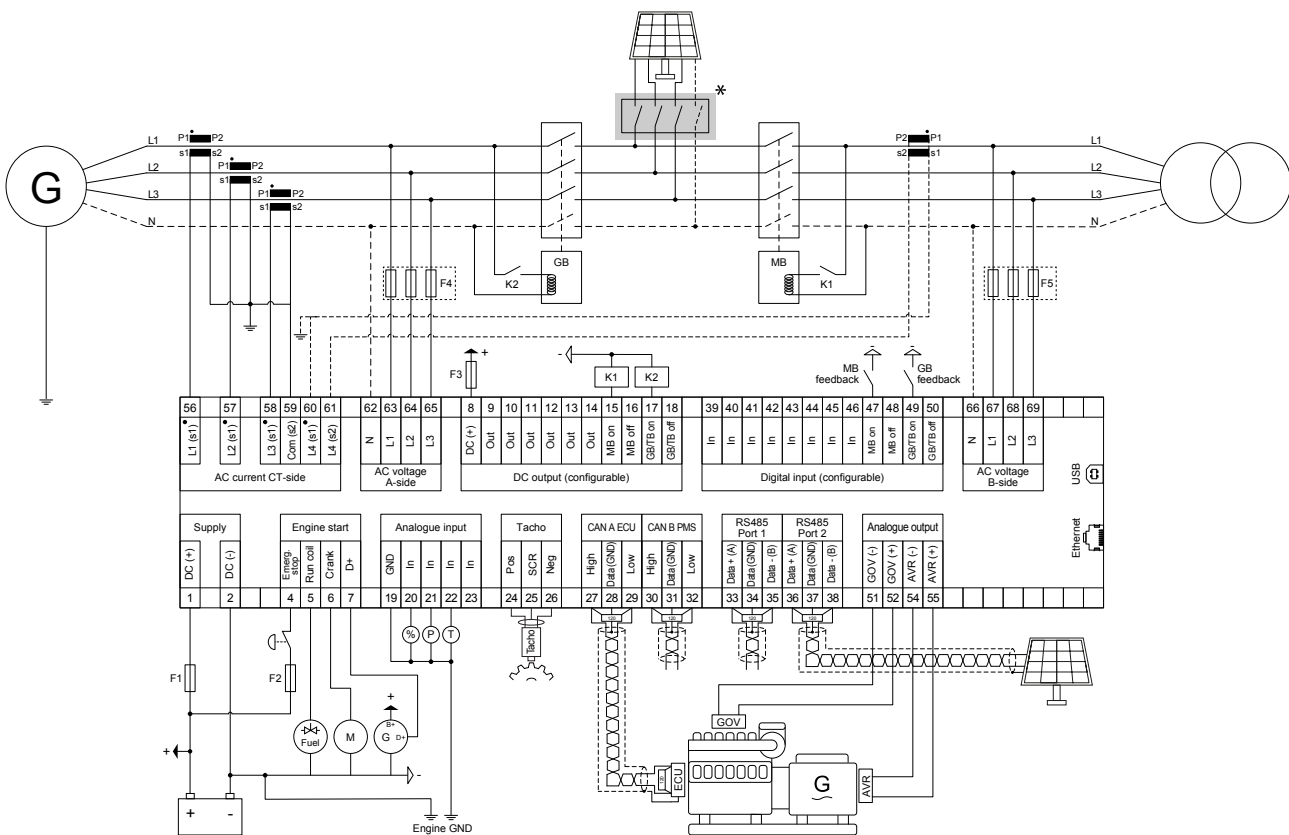

Figure 5.4 Typical wiring for hybrid



NOTE * Optional PV breaker.

Fuses:

- F1, F4, F5: 2 A MCB, c-curve
- F2: 6 A MCB, c-curve
- F3: 4 A MCB, b-curve

5.2 AC connections

5.2.1 AC connections

The AGC 150 can be wired up in three-phase, single phase or split phase configuration. The parameters for setting up the AC connection is found under **Settings > Basic settings > Measurement setup > Wiring connection > AC configuration..**



INFO

Contact the switchboard manufacturer for information about required wiring for the specific application. Wiring suggestions are shown below.

3-phase application

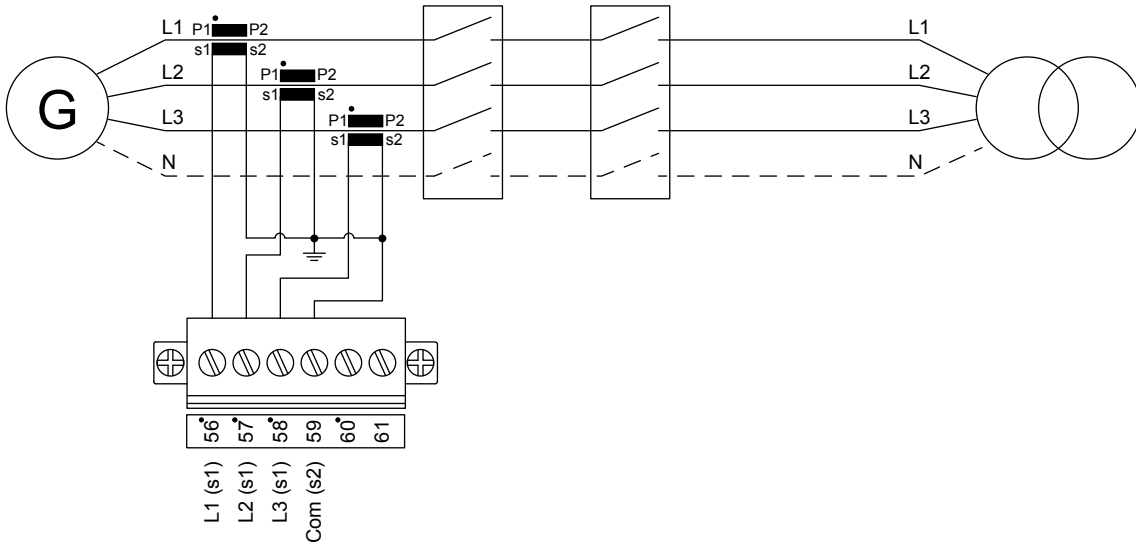

3-phase application (4 wires)

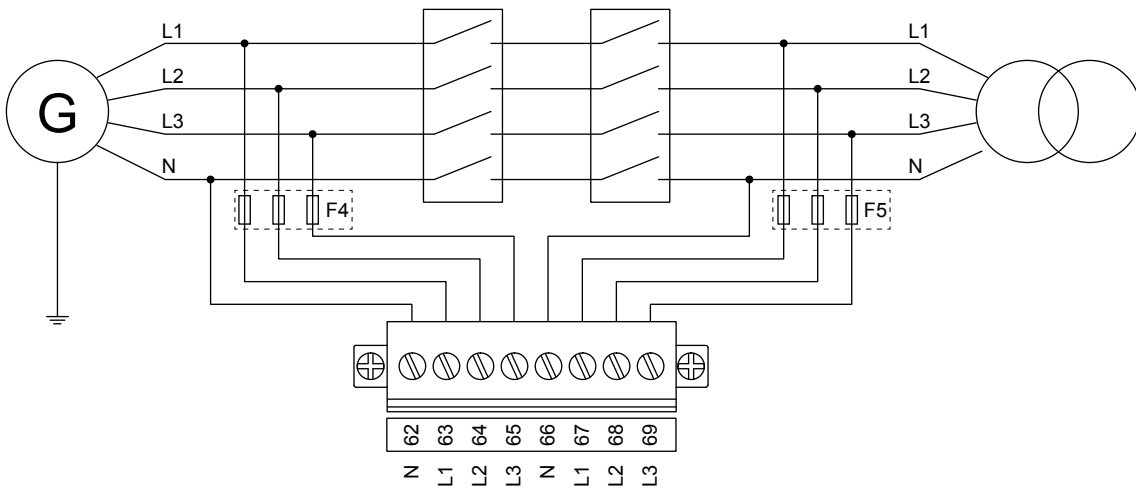

3-phase application (3 wires)

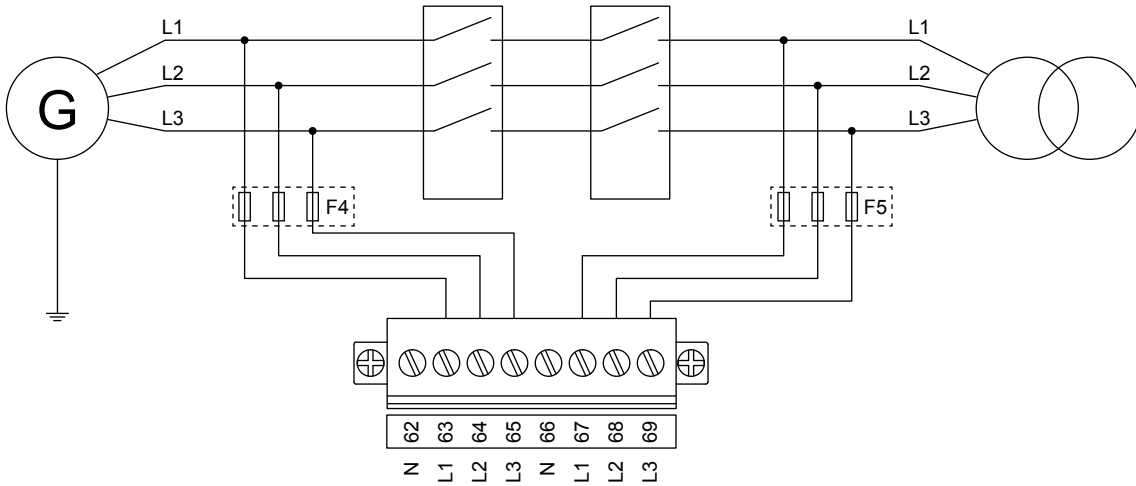

When three-phase distribution systems are used, the neutral line (N) is only necessary if it is a three-phase + neutral system. If the distribution system is a three-phase system without neutral, then do not connect the terminals 62 and 66.

Single-phase application

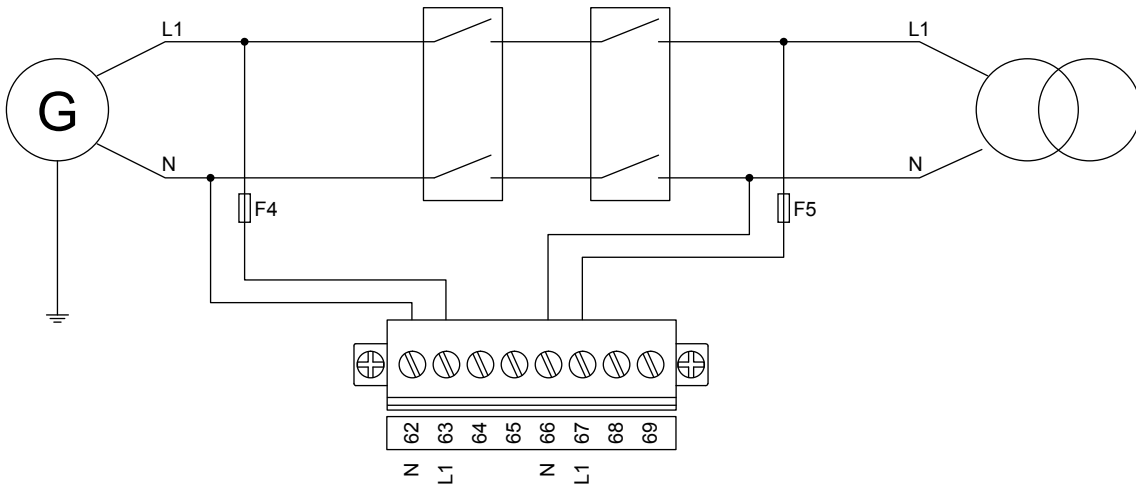

Split phase L1/L2

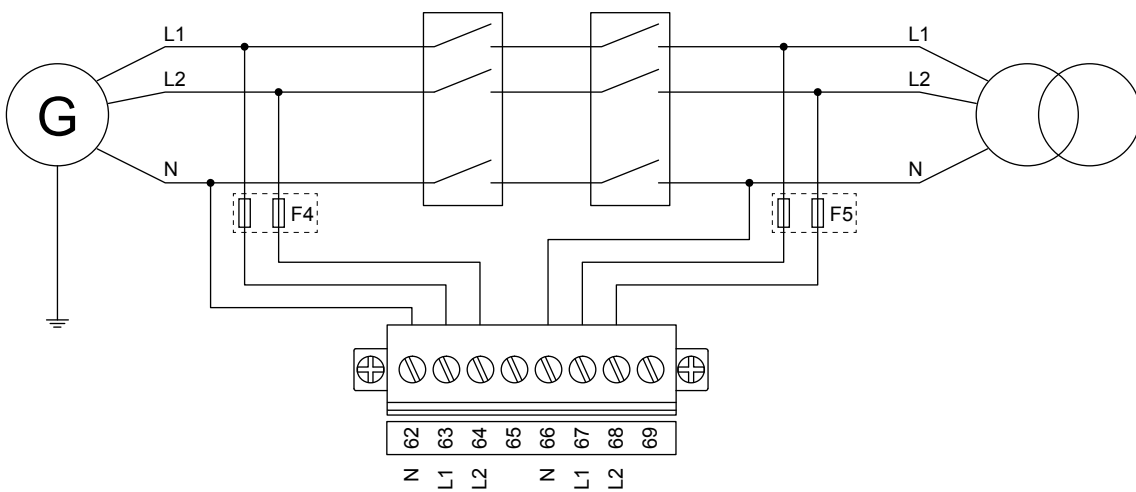

Split phase L1/L3

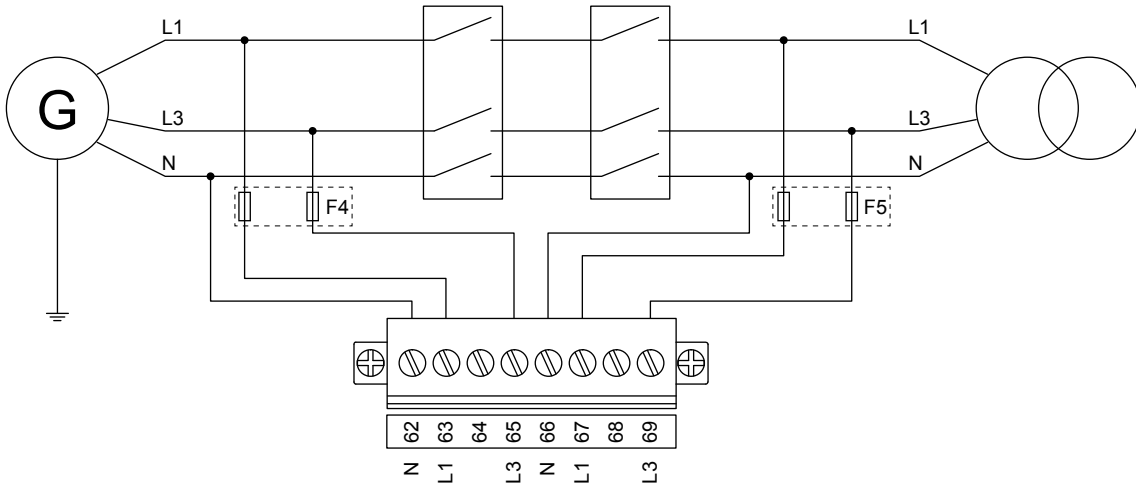

Fuses F4, F5: 2 A MCB, c-curve

5.2.2 I4 current

Neutral/earth current or Mains power

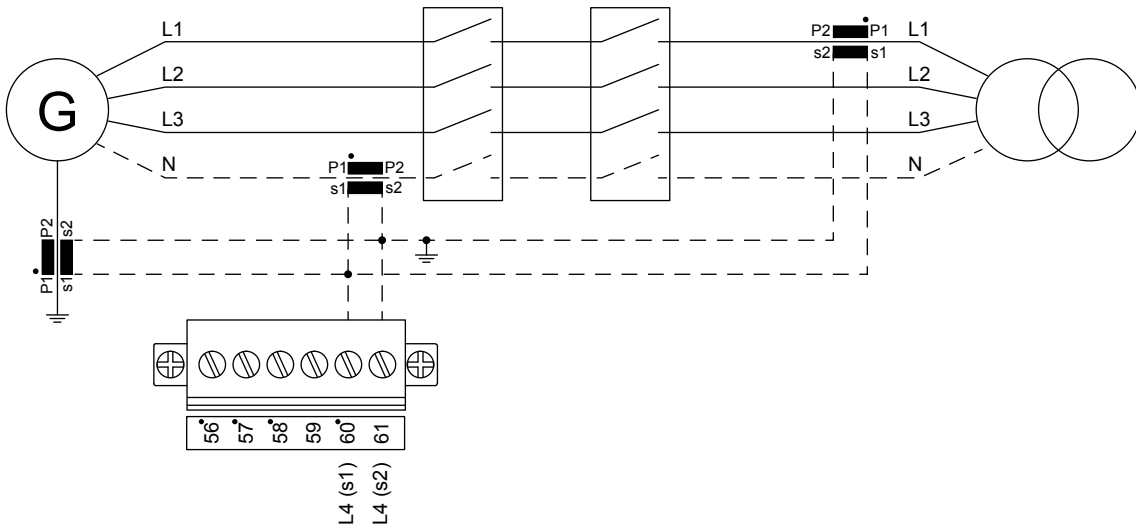

Mains controller tie power

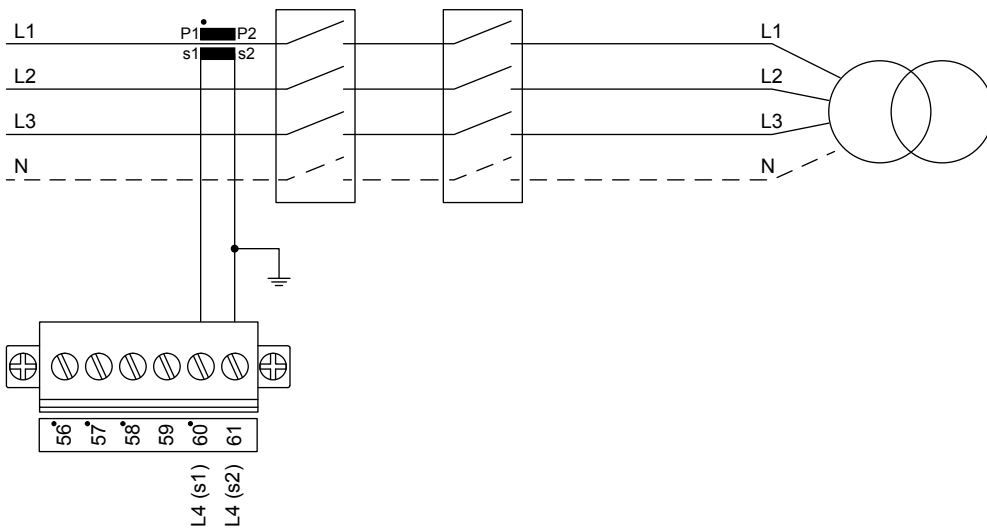

5.2.3 Current transformer ground

The current transformer ground connection must be made on the s2 connection.



DANGER!

Failure to ground the current transformer could lead to injury or death.

5.2.4 Voltage measurement fuses

If the wires/cables must be protected with fuses, use max. 2 A slow blow fuses, dependent on the wires/cables to be protected.

5.2.5 Analogue inputs

Analogue input

All sensors must be wired to the Engine GND.

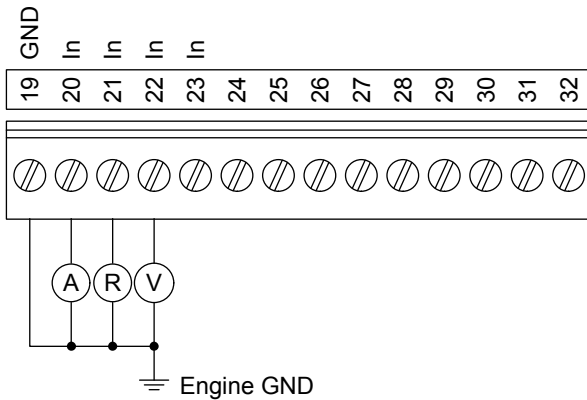

Analogue tacho input (MPU)

Connect the cable shield to terminal 25 (SCR). Do not ground the cable.

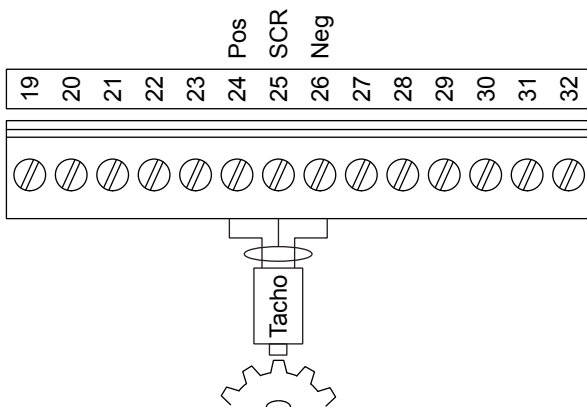

Analogue tacho input (NPN)

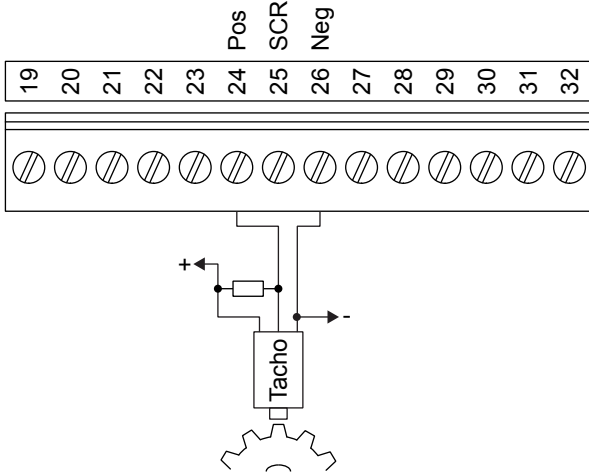

Analogue tacho input (PNP)

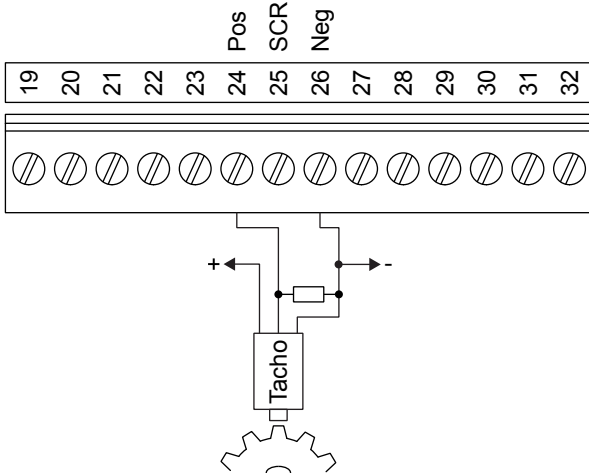

Analogue tacho input (W)

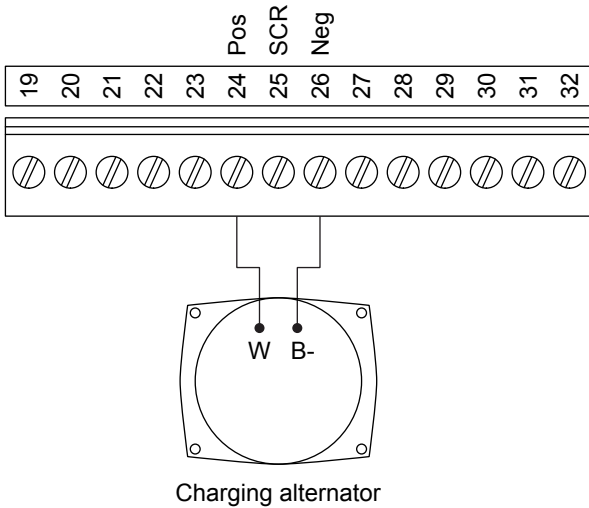

5.3 DC connections

5.3.1 Digital inputs

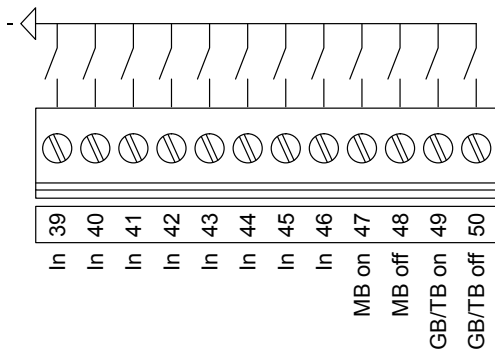

In order to be EN60255 compliant, when wiring is more than 10 m, a 4007 diode must be connected on each input.

5.3.2 Digital outputs

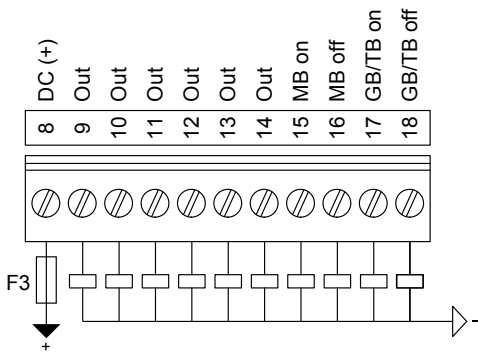

Fuse F3: 4 A MCB, c-curve

5.3.3 Breaker wiring

Pulse breaker wiring

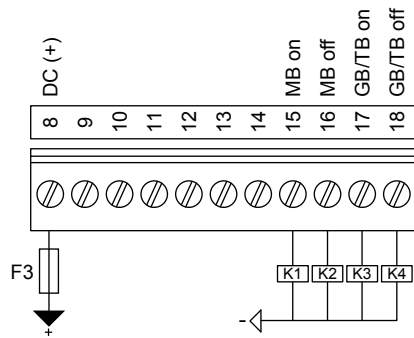
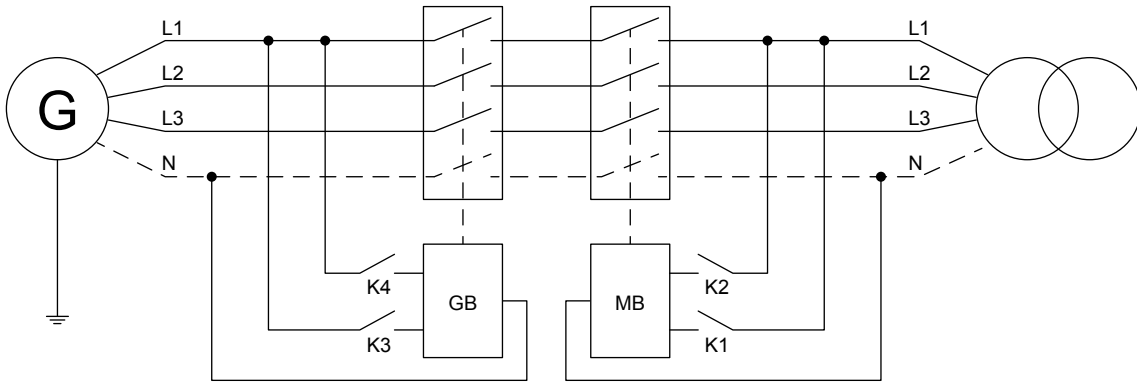

Continuous breaker wiring

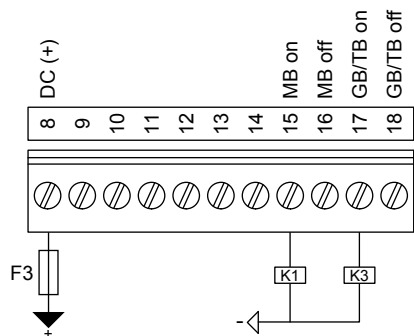
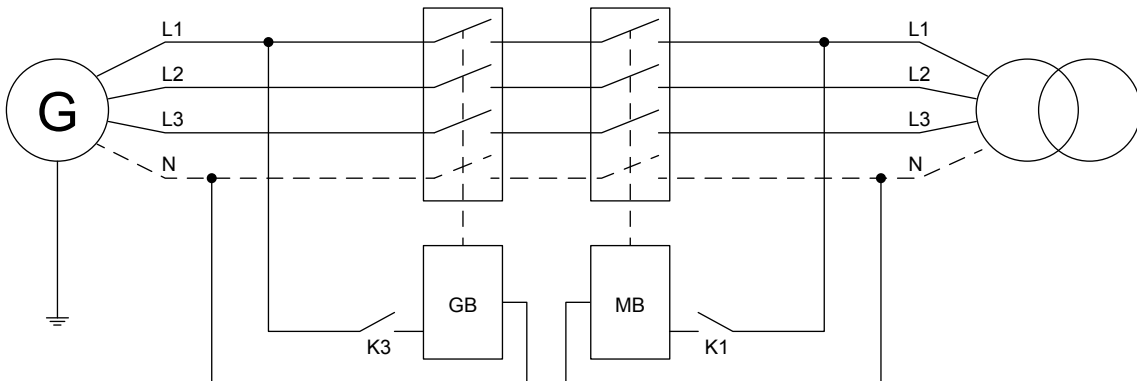

Fuse F3: 4 A MCB, b-curve

5.3.4 Power supply and start

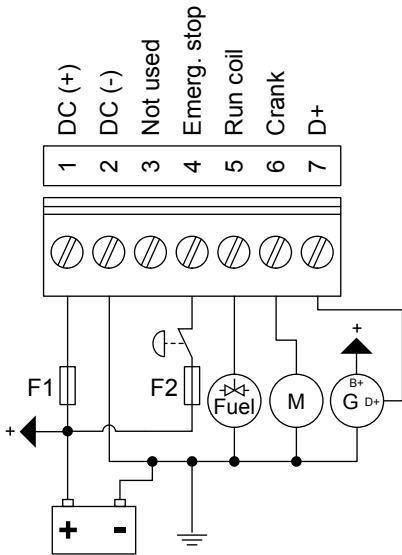

Fuses:

- F1: 2 A MCB, c-curve
- F2: 6 A MCB, c-curve

5.4 Communication

5.4.1 CAN bus power management system

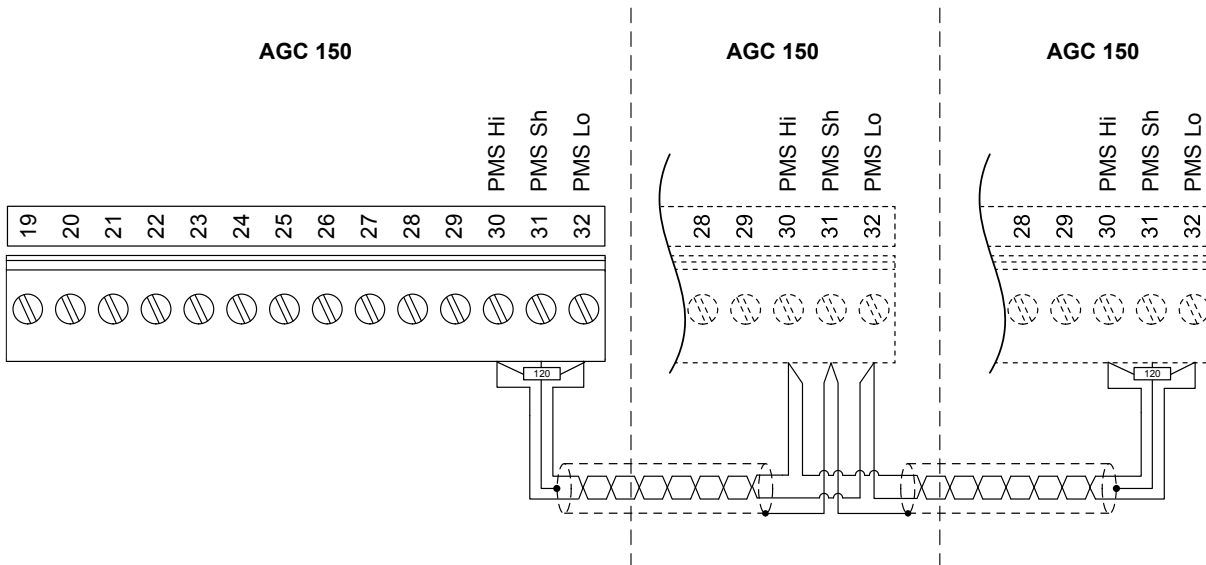

Recommended cable: Belden 3105A or equivalent, 24 AWG (0.5 mm²) twisted pair, shielded, impedance 120 Ω, <40 mΩ/m, min. 95 % shield coverage.

5.4.2 CAN bus engine communication

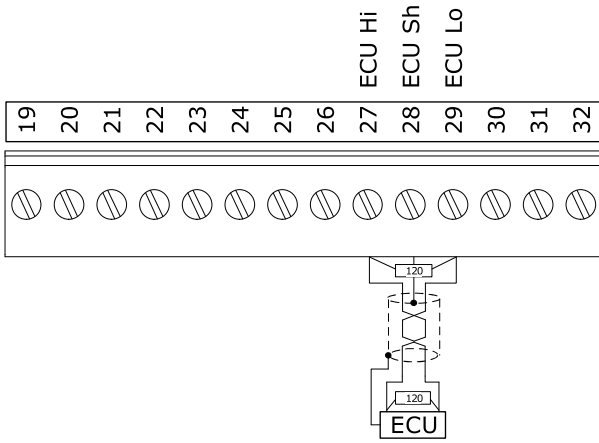

Recommended cable: Belden 3105A or equivalent, 24 AWG (0.5 mm²) twisted pair, shielded, impedance 120 Ω, <40 mΩ/m, min. 95 % shield coverage.

In order to be EN60255 compliant, when wiring is more than 10 m, terminal 28 must be connected to GND.

5.4.3 Modbus RS-485

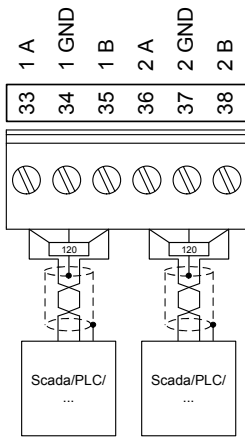

Recommended cable: Belden 3105A or equivalent, 24 AWG (0.5 mm²) twisted pair, shielded, impedance 120 Ω, <40 mΩ/m, min. 95 % shield coverage.

In order to be EN60255 compliant, when wiring is more than 10 m, the terminals 34 and 37 must be connected to GND.